

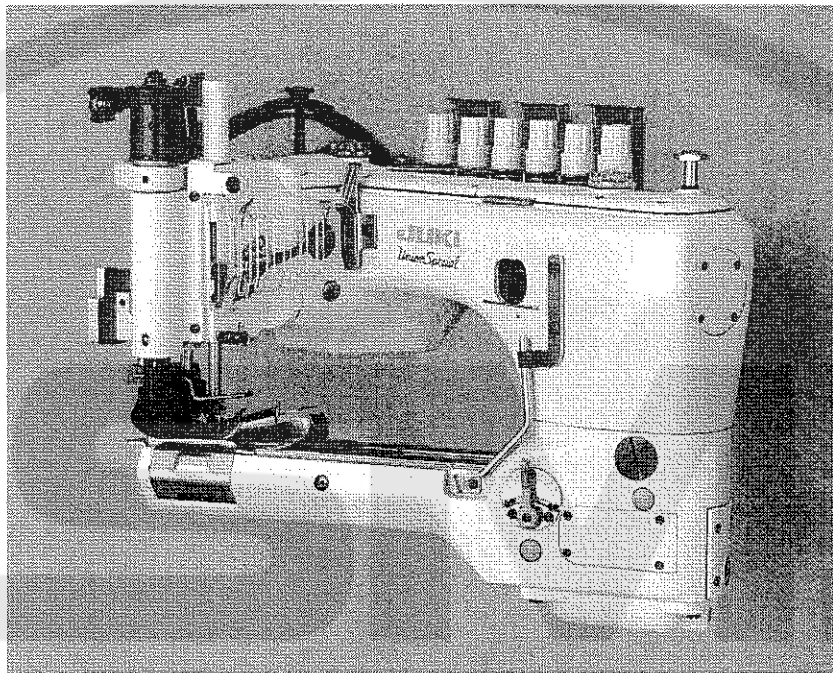

# JUKI

## *Union Special*

ADJUSTING INSTRUCTIONS/ILLUSTRATED PARTS LIST



35800  
High Speed  
Feed- Off- The- Arm  
With  
Plain Feed  
Differential Feed

MANUAL NO. PT9804

### STYLES

35800DLU  
35800DNU  
35800DRU  
35800DRW  
35800DWW  
35800PZ  
35800DZ

## CONTENTS

IDENTIFICATION OF MACHINES .....	5
CLASS DESCRIPTION .....	5
STYLE OF MACHINES .....	5
ILLUSTRATIONS .....	6
IDENTIFYING PARTS .....	6
NEEDLES .....	6
TERMS .....	6
THREADING & OILING FOR PLAIN FEED .....	7
THREADING & OILING FOR DIFFERENTIAL FEED .....	8
NEEDLES .....	9
LUBRICATION .....	9
THREADING .....	9
ADJUSTING INSTRUCTIONS .....	9
TORQUE REQUIREMENTS .....	10
SYNCHRONIZING NEEDLE AND LOOPER MOTIONS .....	10
TIGHTENING NEEDLE HEAD .....	11
ALIGNING NEEDLES IN THROAT PLATE SLOTS .....	11
CENTERING THE CYLINDER .....	11
SETTING THE LOOPER .....	11
SETTING THE LOOPER (CONT.) .....	12
SETTING HEIGHT OF NEEDLE BAR .....	12
SETTING THE FEED DOGS FOR PLAIN FEED .....	12
SETTING THE FEED DOGS FOR DIFFERENTIAL FEED .....	12
SETTING THE FEED DOGS FOR DIFFERENTIAL FEED (CONT.) .....	13
CHANGING STITCH LENGTH .....	13
SETTING REAR NEEDLE GUARD .....	13
PRESSER FOOT AND PRESSER BAR ADJUSTMENT .....	14
UPPER FEED ROLLER ADJUSTMENT .....	14
UPPER FEED ROLLER ADJUSTMENT (CONT.) .....	15
THREAD TENSION AND RELEASE .....	15
DIFFERENTIAL CONTROL .....	15
SETTING NEEDLE THREAD TAKE-UP AND FRAME EYELET .....	16
LOOPER THREAD TAKE-UP ADJUSTMENT .....	16
FOLDER ADJUSTMENT .....	17
AIR BLOWER TUBE ADJUSTMENT .....	17
MAIN FRAME, CAST-OFF PLATE, EYELETS, MISCELLANEOUS COVERS AND BUSHINGS .....	19
MAIN FRAME, CAST-OFF PLATE, EYELETS, MISCELLANEOUS COVERS AND BUSHINGS (CONT.) .....	21
CYLINDER COVERS AND BUSHINGS FOR PLAIN FEED .....	23
CYLINDER COVERS AND BUSHINGS FOR PLAIN FEED (CONT.) .....	25
CYLINDER COVERS AND BUSHINGS FOR DIFFERENTIAL FEED .....	27
CYLINDER COVERS AND BUSHINGS FOR DIFFERENTIAL FEED (CONT.) .....	29
DETACHABLE HEAD ASSEMBLY .....	31
OILING, NEEDLE LEVER, CRANKSHAFT AND MAIN SHAFT PARTS .....	33
PLAIN FEED BAR, FEED LIFT & FEED DRIVE COMPONENTS FOR PLAIN FEED .....	35
DIFFERENTIAL FEED BAR, MAIN FEED BAR, FEED LIFT ECCENTRIC ASSEMBLY FOR DIFFERENTIAL FEED .....	37
FEED DRIVE COMPONENTS, LOOPER DRIVE COMPONENTS AND LOOPERS FOR PLAIN FEED .....	39
LOOPERS, LOOPER HOLDERS, FEED DRIVE COMPONENTS AND LOOPER AVOID COMPONENTS FOR DIFFERENTIAL FEED .....	41
LOOPERS, LOOPER HOLDERS, FEED DRIVE COMPONENT AND LOOPER AVOID COMPONENT FOR DIFFERENTIAL FEED (CONT.) .....	43
UPPER ROLLER FEED, FOOT LIFTER AND THREAD TENSION PARTS .....	45
UPPER ROLLER FEED, FOOT LIFTER AND THREAD TENSION PARTS (CONT.) .....	47
PULLEY, CRANKSHAFT, CLUTCH AND CLUTCH DRIVING MECHANISM .....	49
PULLEY, CRANKSHAFT, CLUTCH AND CLUTCH DRIVING MECHANISM (CONT.) .....	51
SEWING PARTS .....	53
THREAD STAND .....	55
ACCESSORIES .....	56
NUMERICAL INDEX OF PARTS .....	57
NUMERICAL INDEX OF PARTS .....	58
NUMERICAL INDEX OF PARTS .....	59
NOTES .....	60
NOTES .....	61



## SAFETY RULES

1. Before putting the machines described in this manual into service, carefully read the instructions. The starting of each machine is only permitted after taking notice of the instructions and by qualified operators.

**IMPORTANT!** Before putting the machine into service, also read the safety rules and instructions from the motor supplier.

2. Observe the national safety rules valid for your country.
3. The sewing machines described in this instruction manual are prohibited from being put into service until it has been ascertained that the sewing units which these sewing machines will be built into, have conformed with the EC Council Directives (89/392/EEC, Annex II B).

Each machine is only allowed to be used as foreseen. The foreseen use of the particular machine is described in paragraph "STYLES OF MACHINES" of this instruction manual. Another use, going beyond the description, is not as foreseen.

4. All safety devices must be in position when the machine is ready for work or in operation. Operation of the machine without the appertaining safety devices is prohibited.
5. Wear safety glasses.
6. In case of machine conversions and changes all valid safety rules must be considered. Conversions and changes are made at your own risk.
7. The warning hints in the instructions are marked with one of these two symbols:



8. When doing the following the machine has to be disconnected from the power supply by turning off the main switch or by pulling out the main plug:
  - 8.1 When threading needle(s), looper, spreader etc.
  - 8.2 When replacing any parts such as needle(s), presser foot, throat plate, looper, spreader, feed dog, needle guard, folder, fabric guide etc.
  - 8.3 When leaving the workplace and when the workplace is unattended.
  - 8.4 When doing maintenance work.
  - 8.5 When using clutch motors without actuation lock, wait until the motor is stopped totally.
9. Maintenance, repair and conversion work (see item 8) must be done only by trained technicians or special skilled personnel under consideration of the instructions.
10. Any work on the electrical equipment must be done by an electrician or under direction and supervision of special skilled personnel.
11. Work on parts and equipment under electrical power is not permitted. Permissible exceptions are described in the applicable sections of standard sheet DIN VDE 0105.
12. Before doing maintenance and repair work on the pneumatic equipment, the machine has to be disconnected from the compressed air supply. In case of existing residual air pressure, after disconnecting from compressed air supply (i.e. pneumatic equipment with air tank), the pressure has to be removed by bleeding.



## IDENTIFICATION OF MACHINES

Each UNION SPECIAL machine is identified by a style number, which is stamped into the style plate affixed to the middle of the machine under the tension assembly.

The serial number is stamped in the casting at the right rear base of the machine.

### CLASS DESCRIPTION

High Speed, Feed-Off-The-Arm High Throw Machines, Two and Three Needle, Left Needle In Front. Light Weight Presser Bar Mechanism, Adjustable Looper Avoid, Space in Front of Needles 8" (203.2 mm), Single Disc Looper Thread Take-Up, Automatic Enclosed Type Oiling System and Filter Type Oil Pump, Visual Sight Oil Action and Supply Gauges.

### STYLE OF MACHINES

35800DLU	DOUBLE LAP SEAM. Three needle, medium capacity, differential feed with upper driven roller feed. -Typical Application- For in and out seaming on medium weight khaki garments. Seam Specification 401 LSc-3. Standard gauge Number 9 [9/64", 3.6mm]. Recommended needle 130GS, size 110/044. Maximum recommended speed 4500 R.P.M.. .040 step sewing parts. .468 (15/32, 11.9mm) narrow rubber roller.
35800DNU	DOUBLE LAP SEAM. Three needle, high capacity, differential feed with upper driven roller feed. -Typical Application- For in and out seaming on heavy weight denim garments. Seam Specification 401 LSc-3. Standard gauge Numbers 8 [1/8", 3.2mm] and 9 [9/64", 3.6mm]. Recommended needle 130GS, size 140/054. Maximum recommended speed 4500 R.P.M.. .094 step sewing parts. .468 (15/32, 11.9mm) narrow roller.
35800DZ	Same as 35800DNU except with reverse teeth roller.
35800DRU	DOUBLE LAP SEAM. Three needle, high capacity, plain feed, upper driven, roller feed. Feed Dogs have higher teeth on front. - Typical Application- For seat seaming, in and out seams on medium to heavy weight denim garments. Seam Specifications 401LSc-3. Standard gauge Numbers 8 [1/8", 3.2mm] and 9 [9/64", 3.6mm]. Recommended needle 130GS, size 140/054. Maximum recommended speed 4500 R.P.M.. .094 step sewing parts. .468 (15/32", 11.9mm) narrow roller.
35800PZ	Same as 35800DRU except with reverse teeth roller.
35800DRW	DOUBLE LAP SEAM. Three needle, high capacity, plain feed, upper driven, roller feed (wide roller). Feeds have higher teeth on front of feeds. - Typical Application- For seat seaming, in and out seams on medium to heavy weight denim garments. Seam Specifications 401LSc-3. Standard gauge 9 [9/64", 3.6mm]. Recommended needle 130GS, size 140/054. Maximum recommended speed 4500 R.P.M.. .094 step sewing parts. .588" (19/32", 15mm) wide roller.
35800DWW	DOUBLE LAP SEAM. Three needle, high capacity, differential feed, high lift feed eccentric, with upper driven, roller feed (wide roller). Feeds have higher teeth on front of feeds. - Typical Application- For use on heavy weight denim garments. Seam Specifications 401LSc-3. Standard gauge Numbers 8 [1/8", 3.2mm] and 9 [9/64", 3.6mm]. Recommended needle 130GS, size 140/054. Maximum recommended speed 4500 R.P.M.. .094 step sewing parts. .588" (19/32", 15mm) wide roller.



## ILLUSTRATIONS

This manual has been arranged to simplify ordering repair parts. Exploded views of various sections of the mechanism are shown so that the parts may be seen in their actual position in the machine. On the page opposite the illustration will be found a listing of the parts with their part numbers, description and the number of pieces required in the particular view being shown.

Numbers in the first column are reference numbers only, and merely indicate the position of the part in the illustration. The reference number should never be used in ordering parts. Always use the part number listed in the second column.

Component parts of sub-assemblies which can be furnished for repairs are indicated by indenting their descriptions under the description of the main sub-assembly. As an example refer to the following text.

9.	29126 EC	Upper Looper Drive Shaft Assembly .....	1
10.	22503 F	Screw .....	1
11.	39543 E	Cam Follower Locking Clamp .....	1

It will be noted in the previous example that the cam follower, bushing and cam guide and the upper looper drive shaft are not listed. The reason is that replacement of these parts individually is not recommended, so the complete upper looper drive shaft assembly should be ordered.

When a part is common to all machines covered in this manual, no specific usage will be mentioned in the description. However, when the parts for the various machines are not the same, the specific usage will be mentioned in the description and, if necessary, the difference will be shown in the illustration.

A numerical index of all the parts shown in this manual is located at the back. This will facilitate locating the illustration and description when only a part number is known.

## IDENTIFYING PARTS

Where the construction permits, each part is marked with its part number. On some of the smaller parts and on those where construction does not permit, an identification letter is marked in to distinguish the part from similar ones.

PLEASE NOTE: Part numbers represent the same part, regardless of which manual they appear. On all orders please include part number, name and style of machine for which the part was ordered.

## NEEDLES

Each needle has both a type and size number. The type number denotes the kind of shank, point, length, groove, finish and other details. The size number, stamped on the needle shank, denotes the largest diameter of the blade measured between the shank and the eye. Collectively, the type number and size number represent the complete symbol which is given on the label of all needles packed and sold by Union Special.

<u>TYPE</u>	<u>DESCRIPTION</u>
130 GS	Short, double groove, struck groove, ball eye, spotted, government point, chromium plated- Sizes available 080/032, 090/036, 100/040, 110/044, 125/049, 140/054, 150/060.

To have needles promptly and accurately filled, an empty package, a needle sample, or the type and size number should be forwarded. Use the description on the label. A complete order should read as follows: "100 needles, type 130 GS, size 125/049".

## TERMS

Prices are net cash and subject to change without notice. All shipments are forwarded F.O.B. shipping point. A charge is made to cover postage and insurance.



# THREADING & OILING FOR PLAIN FEED

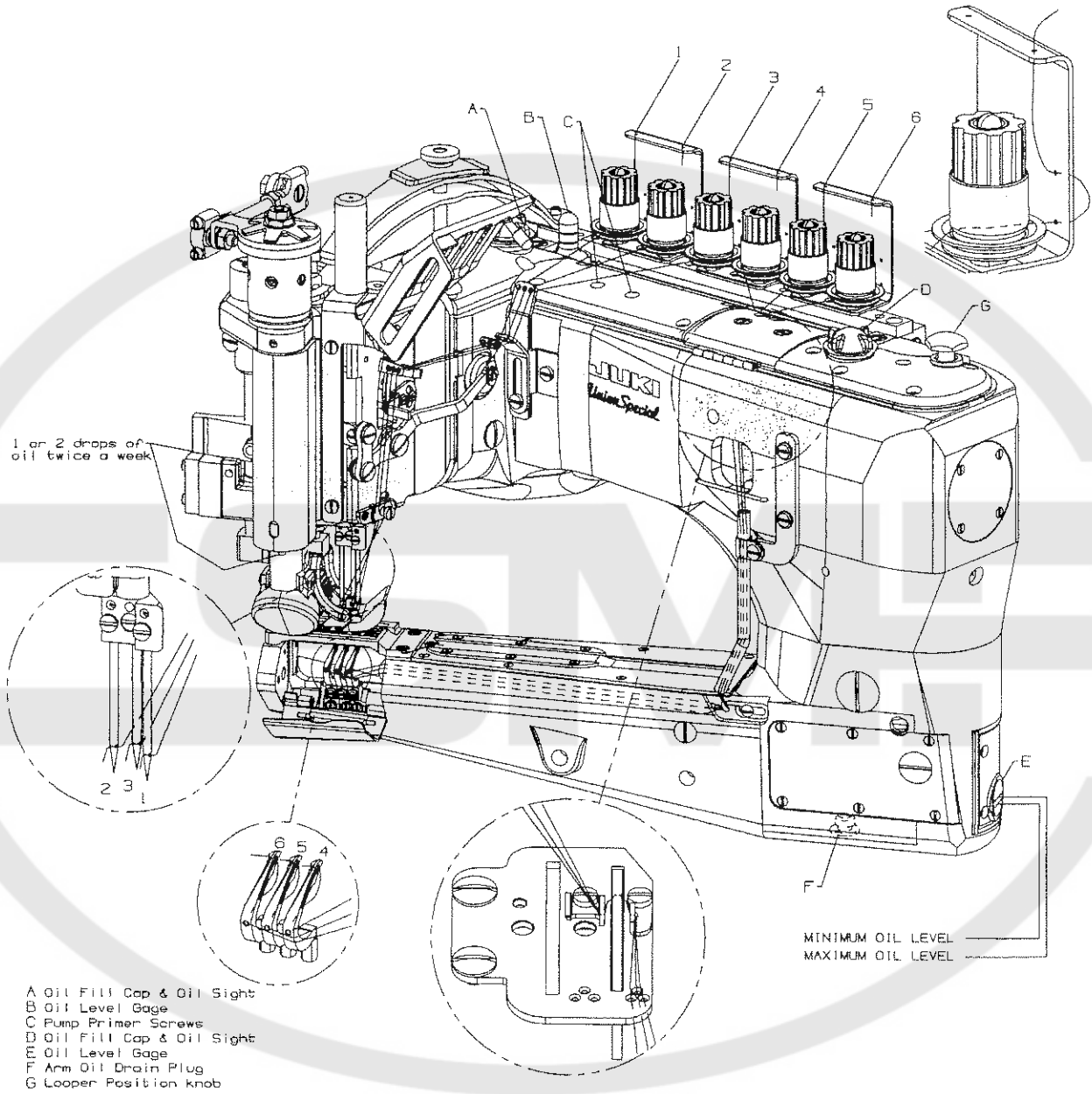

FIG. 1

# THREADING & OILING FOR DIFFERENTIAL FEED

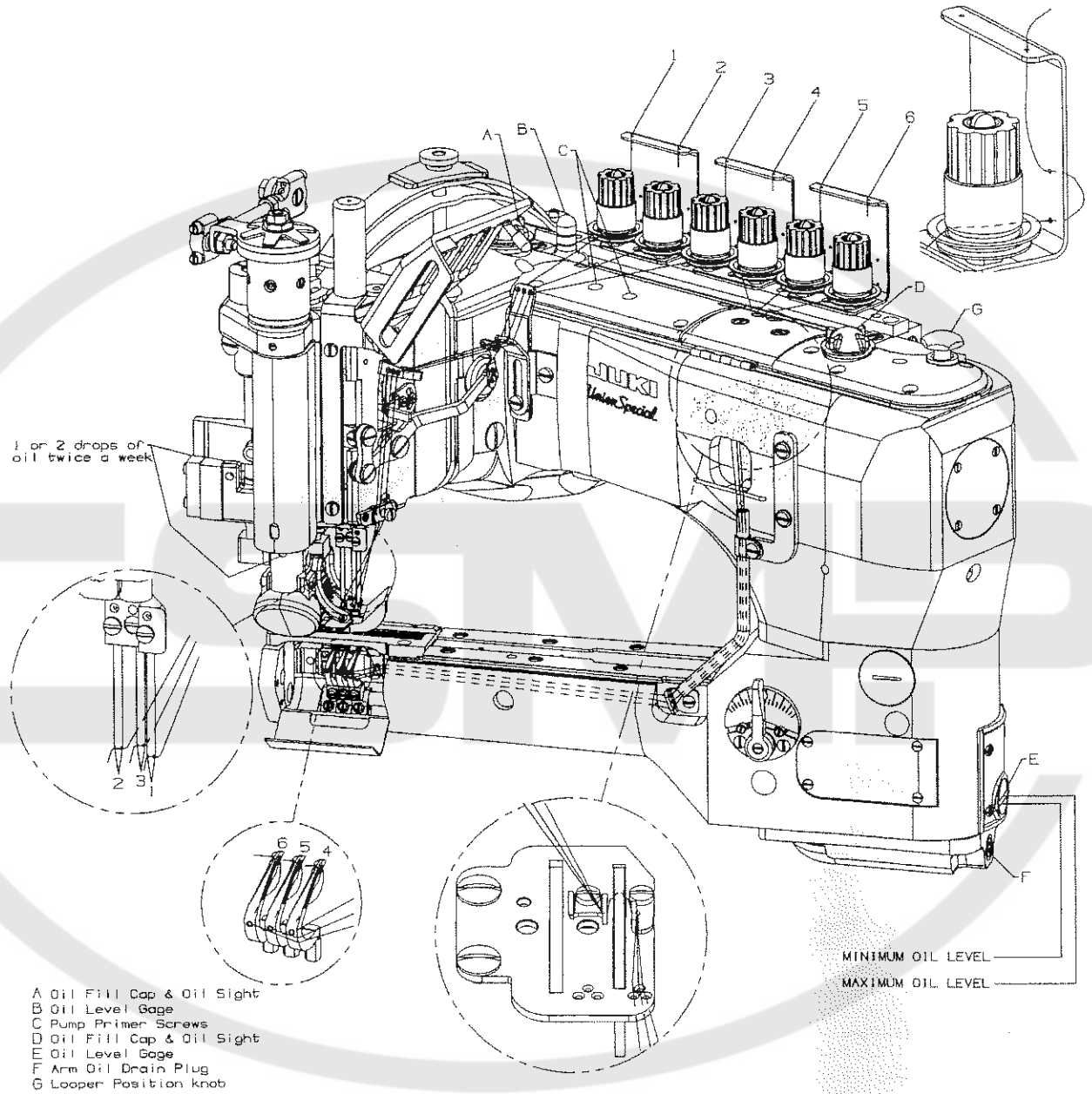

FIG. 1



Needle Type	Description	Sizes Available
130GS	Short double groove, struck groove, ball eye, spotted, government point, chromium plated.	080/032, 090/036, 100/040, 110/044, 125/049, 140/054, 150/060

Table I

## NEEDLES

Selection of proper needle size is determined by size of thread used. Thread should pass freely through the needle eye in order to produce a good stitch formation.

Each needle has both a type and size number. The type number denotes the kind of shank, point, length, groove, finish and other details. The size number, stamped on the needle shank, denotes largest diameter of blade, measured midway between shank and eye. Collectively, type and size number represent the complete symbol which is given on the label of all needles packaged and sold by UNION SPECIAL. See "STYLE OF MACHINES" for the standard recommended needle type & size for your machine.

To have needle orders promptly and accurately filled, an empty package, a sample needle, or the type and size number should be forwarded. Use the description on the label. A complete order would read: "1000 Needles, Type 130GS, Size 140/054".

## LUBRICATION

The oil has been drained from the machine before shipping and the reservoirs must be filled before beginning to operate. Use a straight mineral oil with a Saybolt viscosity of 90 to 125 seconds at 100° Fahrenheit. Union Special Part No. 28604R.

Oil is filled at oil caps (A & D, Fig. 1). The level is checked at sight gauges (B) and (E). Maintain the oil level between the red lines of the gauges.

The machine is equipped with a continuous running rotary driven oil pump. The action of the oil can be observed through oil sight (A) and (D) in the front and back top covers.

When starting a new machine, filling the reservoirs or when beginning to operate a machine that has been idle for some time, it may be necessary to prime the pump. To do this, remove the two plug screws (C). Apply oil to these holes and operate machine until bubbling can be observed at the windows. Replace screws (C).

**CAUTION:** If oil does not bubble when machine is running, the circulating pump is inoperative.

Oil may be drained from the machine at two places, plug screw (F) located in the bottom of the cylinder and plug screw (G) at the back of the main frame below the handwheel.

## THREADING

A convenient means for threading the looper has been provided. When loopers are at the left end of their travel, press the knob (H, Fig. 1) and loopers will back out of position, leaving them easily accessible. Thread the machine as illustrated in (Fig. 1). After threading, push loopers back into position.

## ADJUSTING INSTRUCTIONS

**NOTE:** Instructions stating direction of location, such as right, left, front or rear of machine, are given relative to operator's position at the machine. The handwheel rotates counterclockwise, in operating direction; when viewed from the right end of machine.

## TORQUE REQUIREMENTS





Torque specifications given in this catalog are measured in inch-pounds or Newton-meters. All straps and eccentrics must be tightened to 19-21 in. lbs. (2.1-2.3Nm) unless otherwise noted. All nuts, bolts, screws, etc., without torque specifications must be secured as tightly as possible, unless otherwise noted. Special torque specifications for connecting rods, links, screws etc., are shown on the parts illustrations.

## SYNCHRONIZING NEEDLE AND LOOPER MOTIONS

**NOTE:** Needle and looper mechanisms are carefully synchronized with precision gauges before leaving the factory to insure the best possible sewing conditions.

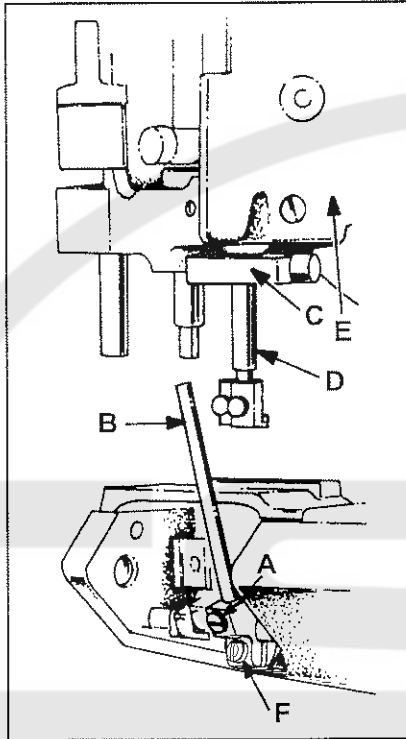

FIG. 2

Should it become necessary to disassemble the main shaft or replace components of the needle or looper drive mechanisms, re-synchronization of the machine will be required to facilitate proper sewing adjustments. This is accomplished by means of an adjustable split coupling located beneath the rear top cover, connecting the crankshaft to the main shaft, which in turn drives the looper mechanism.

To synchronize the machine, remove the needles, presser foot, throat plate, feed dogs and upper feed roller mechanism. Rotate handwheel in the operating direction until the needle bar is at the bottom of its stroke and just begins its upward travel. Loosen screw (A, Fig. 2) and remove the looper for the left hand needle from the looper holder. Insert a straight steel rod (B)  $5/32$ " (3.9mm) or  $11/64$ " (4.3mm) diameter by  $2-1/2$ " (63.5mm) long into looper holder and retighten screw (A). Rotate the handwheel until the rod (B) is at the extreme left and reinstall the throat plate. Loosen screw (F) in looper holder and move the holder left or right until the right side of the rod is approximately  $5/32$ " (4.0mm) from the left edge of the throat plate, tighten screw (F). Turn the handwheel in the operating direction, with needle bar rising until rod (B) comes in contact with the edge of the throat plate. At this point, clamp Union Special timing gauge No. TT147 (C) around the needle bar (D), flush against the underside of the machine casting (E). Rotate handwheel in the opposite direction until either the gauge contacts the machine casting on the up stroke of the needle bar or the rod contacts the edge of the throat plate. Maximum allowable clearance between gauge and casting or rod and throat plate is .005" (0.1mm)

If machine is not synchronized the following applies:

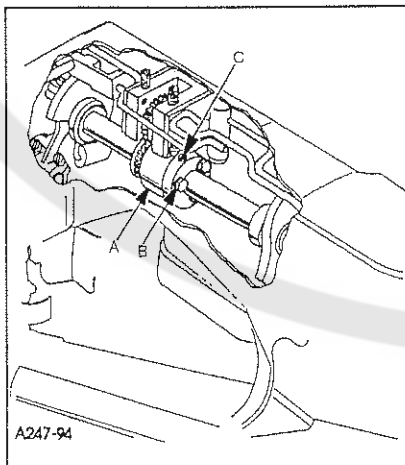

FIG. 3

Both ends of the adjustable split coupling are secured to the crankshaft and main shaft by spot screws and set screws. On the main shaft end of the coupling (A, Fig. 3) three screws (B) thread horizontally through the coupling. The holes in the main shaft end of the coupling are larger than the diameter of the screws, permitting several degrees of rotation in either direction to properly synchronize the needle and looper. Loosen the three horizontal clamp screws (B, Fig. 3). With rod (B, Fig. 2) at its farthest position to the left, snug the uppermost horizontal clamp screw enough to hold coupling (A, Fig. 3) in position. If the handwheel is turned in reverse of operating direction and gauge (C, Fig. 2) on needle bar (D) contacts the machine casting (E) before rod (B) contacts the edge of the throat plate, loosen horizontal clamp screw (B, Fig. 3) which was snug, while holding the coupling in place with an Allen wrench in set screw (C). Rotate the handwheel slightly in reverse of operating direction, snug the uppermost horizontal clamp screw (B), recheck synchronization. If the handwheel is turned in reverse of operating direction and the rod contacts the edge of the throat plate before the clamp gauge contacts the machine casting, adjust as before, except turn the handwheel slightly in the operating direction. Use shim stock to insure no more than .005" (0.1mm) exists between gauge and casting or between rod and throat plate, in

both the operating and reverse directions of the handwheel. When this setting has been made, tighten the three horizontal clamp screws (B, Fig. 3) securely, and recheck both clearance points with .005" (0.1mm) shim gauge to assure no slippage occurred while tightening the screws.



## TIGHTENING NEEDLE HEAD

When replacement of the needle bar, and or needle head is necessary, torque the needle head to needle bar 14-16 in. lbs. (1.6-1.8Nm) or use torque rod No. 21227AR that has been supplied with the machine, for the purpose of eliminating the possibility of distorting the needle bar due to overtightening. Insert the torque rod in the hole at the upper end of the needle bar, while holding the needle bar head with a suitable tool, turn the needle bar with the torque rod onto the needle bar head. When the rod starts to bend, the needle bar head has been threaded into the needle bar properly.

## ALIGNING NEEDLES IN THROAT PLATE SLOTS

Insert a new set of needles, type and size specified, with screw (B, Fig. 4) slightly loosened, lower needle bar (A) and turn needle head as required until the needles are centered in the throat plate needle hole slots. Tighten screw (B) torque to 19-21in.lbs. (2.1-2.4Nm).

**NOTE:** If the needles can not be aligned in the throat plate slots, the lower cylinder must be moved as stated below.

## CENTERING THE CYLINDER

Remove the top front cover and gasket from the main frame. Loosen cylinder holding screw (A, Fig. 5). Turn eccentric screw (B) clockwise or counterclockwise to move the cylinder so the needles are centered in the needle holes. Tighten screws (A) torque to 18 ft.lbs. and recheck settings.

**NOTE:** The cylinder may not move freely when the eccentric is turned because the joint sealant compound has set.

## SETTING THE LOOPER

Insert a new set of needles, type and size specified. Always adjust the looper (A, Fig. 6) for the left needle first. Set the looper so that the distance from the center of the needle (B) to the point of the looper (A) is 9/64" (3.6mm) when the looper is at its farthest position to the left. Looper gauge (C) No. 21225-9/64 can be used advantageously in making this adjustment. If adjustment is required, loosen screw (A, Fig. 7) in looper holder, permitting movement in either direction to attain the 9/64" (3.6mm) dimension as shown in Fig. 6. Retighten screw (A, Fig. 7). Repeat for other needles and loopers.

Rotate handwheel in operating direction to assure that the looper point passes to the rear of the needle to touch but not deflect. This adjustment can be made by loosening screw (A, Fig. 7) in looper holder. Looper holder can be moved front to back to attain looper to needle setting. Always check the 9/64" (3.6mm) looper gauge setting after setting the looper to the back of the needle, and conversely, always check the setting of the looper to the back of the needle after setting the 9/64" (3.6mm) looper gauge.

The amount of looper avoid has been set at the factory to .110" (2.8mm). If it becomes necessary to adjust the amount of avoid it is recommended as a starting point, to have the points of the descending needles contact the back of the lower 1/3 of the back of the looper blade.

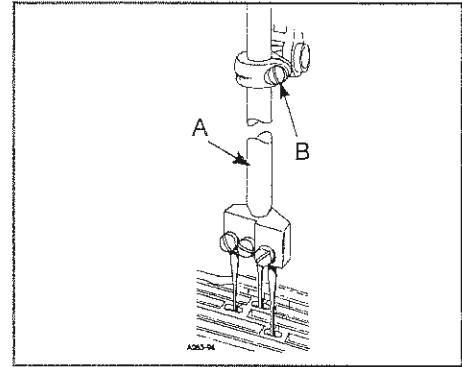
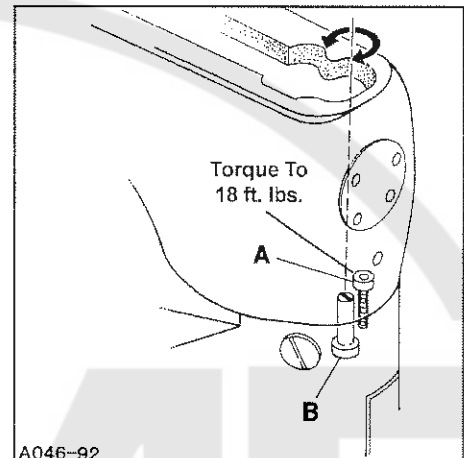
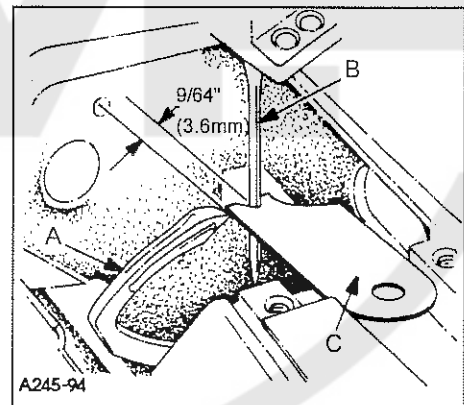

FIG. 4



A046-92

FIG. 5



A245-94

FIG. 6

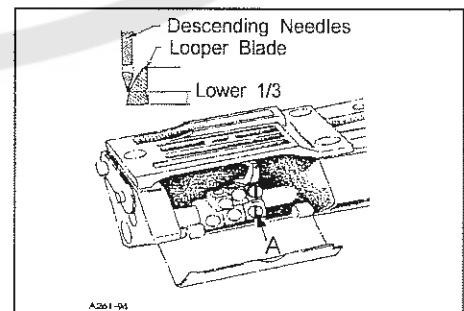

A261-94

FIG. 7

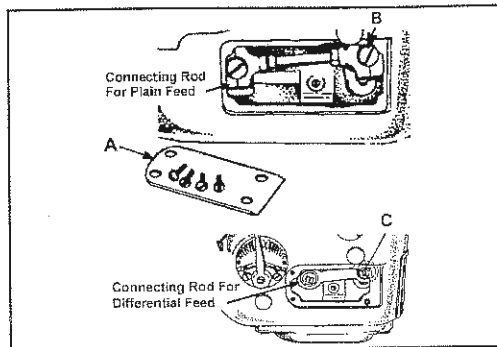

FIG. 8

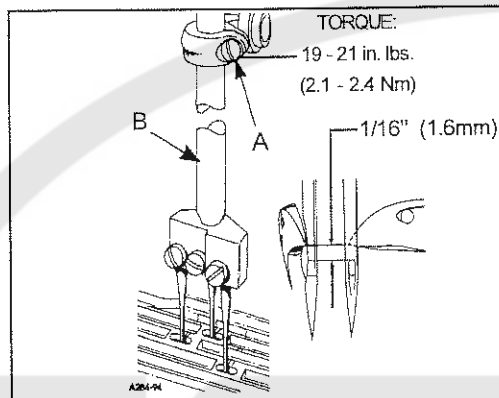

FIG. 9

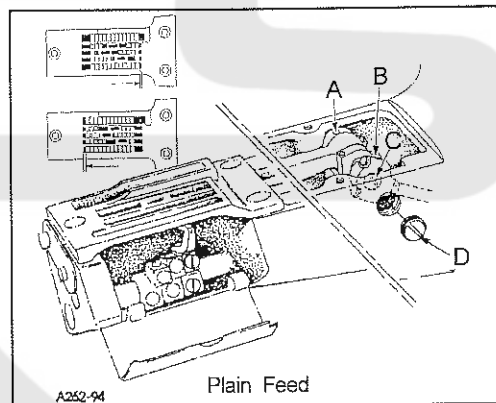

FIG. 10

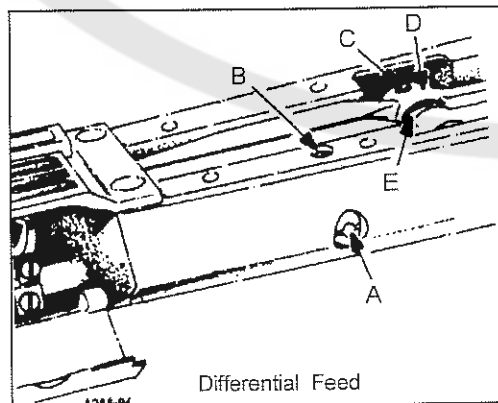

FIG. 10A

### SETTING THE LOOPER (CONT.)

If more or less looper avoid motion is required, remove cylinder side cover (A, fig. 8) located at the lower front left side. For plain feed use a screwdriver to loosen looper avoid link ball joint (B). For differential feed use Union Special wrench TT85 and loosen screw stud (C) Moving ball joint down in the lever slot increases the amount of looper avoid motion, moving it up acts the reverse. Retighten ball joint (B), or screw stud (C) securely.

NOTE: Whenever looper avoid is changed looper clearance to needle must also be reset.

### SETTING HEIGHT OF NEEDLE BAR

The height of the needle bar is correct when the top of the needle eye is  $1/16$ " (1.6mm) below the underside of the looper, with the looper point even with the right side of the needle. To make adjustment loosen screw (A, Fig. 9) and move needle bar (B) as required to attain dimension.

NOTE: Care must be taken not to disturb the alignment of the needles when moving the needle bar either up or down.

### SETTING THE FEED DOGS FOR PLAIN FEED

Assemble the main feed dog and throat plate. Main feed dog (A, Fig. 11) at its highest position, should be set to project above the throat plate, the depth of its teeth. The feed dog mounting screw (B) and front support screw (C) should be set to maintain this setting.

The feed should be set so there is equal clearance between the front of the feed dog and the front of the feed slot in the throat plate when the feed dog is at its most forward travel. The same amount of clearance should be between the back of the feed dog and the back of the feed slot in the throat plate when the feed dog is at its most rearward travel. To attain this setting loosen screws (A and B, Fig. 10) and remove plug screw (D). Using a screw driver turn eccentric pin (C) clockwise or counter-clockwise to obtain proper setting. Tighten screws (A and B), reinstall plug screw (D).

### SETTING THE FEED DOGS FOR DIFFERENTIAL FEED

Before assembling the main and differential feed dogs, set the feed bar eccentric pin (A, Fig. 10A) located in the left side near center of cylinder, so that the slot in the head is in a horizontal position for the 35800DLU, DNU, and DZ style machines and turned counter clockwise to an approximate  $45^\circ$  for the 35800DWW style of machine. The pin can be used to slightly tilt both feed dogs if necessary. The feed bar pin is retained in position by set screw (B). Assemble differential feed dog (A, Fig. 11A), main feed dog (B) and throat plate. Both the main and differential feed dogs can be individually adjusted to height. Main feed dog (B) at its highest position, should be set to project above the throat plate, the depth of its teeth. If adjustment is necessary loosen screw (D) and move feed dog (B) up or down to attain correct setting. Feed dog support (C) should support front of feed dog.

NOTE: If eccentric pin (A, Fig. 10A) is used to tilt the feed dogs, make sure that the looper does not interfere with the rear needle guard and that the needle guard does not pinch the needle loops on the back side of the needles.



## SETTING THE FEED DOGS FOR DIFFERENTIAL FEED (CONT.)

If adjustment is necessary loosen screw (E, Fig. 11A) in feed dog support (C) and move as required. Retighten screw (E). The differential feed dog (A) may then be leveled with main feed dog (B). If adjustment is necessary loosen screw (F) and move feed dog up or down as required. Retighten screw (F).

**NOTE:** Should the main feed dog require repositioning due to contact with the throat plate in its forward or rearward travel, loosen set screw (C, Fig. 10A) in main feed bar driving link (D), rotate main feed bar eccentric driving stud (E) as required. Driving stud (E) has a thin hexagon head with cutouts on two of the flats allowing movement by tapping with a sharp pointed tool, when wrench 21388AZ is not available. Whenever the main feed bar eccentric driving stud position has been changed, recheck rear needle guard setting, adjustment may be required. Retighten set screw (C). Position main feed dog support (C, Fig. 11A) flush against bottom of main feed dog (B), tighten support screw (E) securely.

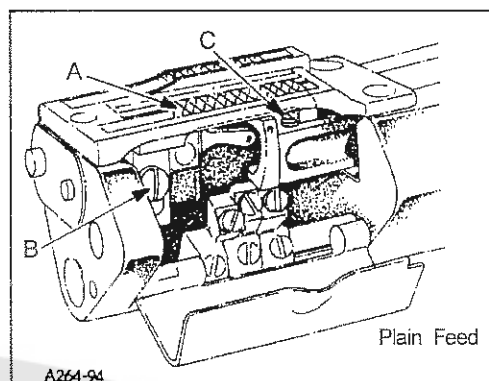

FIG. 11

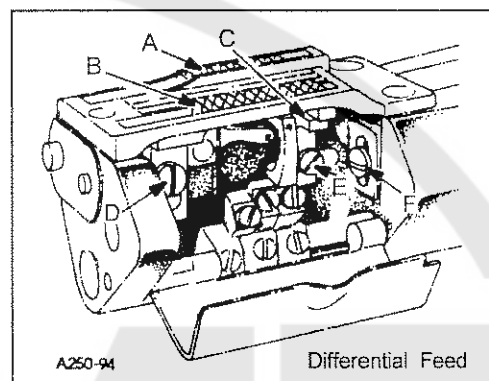

FIG. 11A

## CHANGING STITCH LENGTH

When change in stitch length is required, remove large plug screw (A, Fig. 12). Loosen feed rocker driving link screw (B) in lever (C). Moving the feed rocker driving link up in the lever slot lengthens the stitch, moving it down, shortens the stitch. Retighten link screw (B) securely and replace plug screw (A).

**NOTE:** If plug screw (A) is replaced with a new plug screw, it should be sealed with a silicone seal.

Any stitch length change, requires resetting the needle guard.

**CAUTION:** When making stitch length adjustment do not exceed maximum recommended stitch length due to possible part damage.

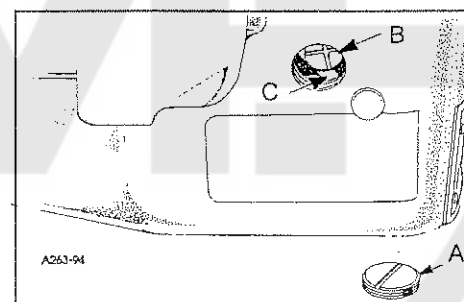

FIG. 12

## SETTING REAR NEEDLE GUARD

Set the rear needle guard (A, Fig. 13) horizontally to touch and possibly deflect slightly to obtain solid guarding of all needles (B) when at its extreme forward position. If adjustment is necessary loosen screw (E) and move guard front to back as required. It should be set vertically as low as possible, yet have its guarding surface in contact with the needles until the points of the loopers (C), moving to the right, are even with the right side of the needles. If adjustment is necessary loosen screw (F) and move guard and holder up or down as required.

**CAUTION:** If stitch length is changed, needle guard must be reset.

**NOTE:** When installing the needle it should be parallel with the eye in line of feed. If adjustment is necessary, loosen screw (N, Fig. 15) in needle head and rotate needle to attain adjustment (D, Fig. 13).

**NOTE:** Looper closeness to needles as described on page 11 must be maintained after rear needle guard is adjusted. Readjust loopers as necessary.

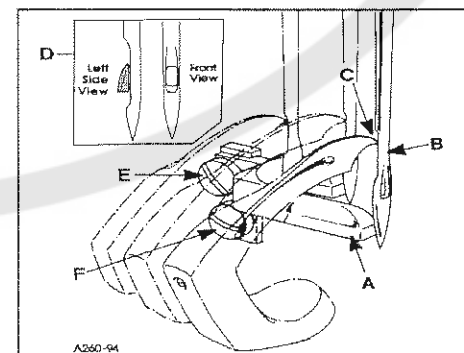

FIG. 13

## PRESSER FOOT AND PRESSER BAR ADJUSTMENT

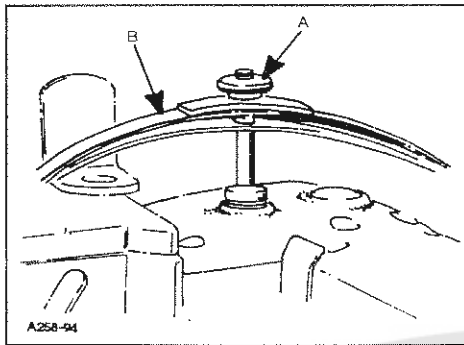

FIG. 14

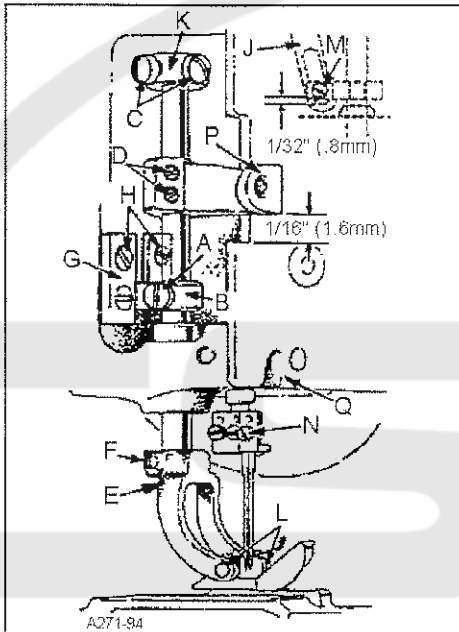

FIG. 15

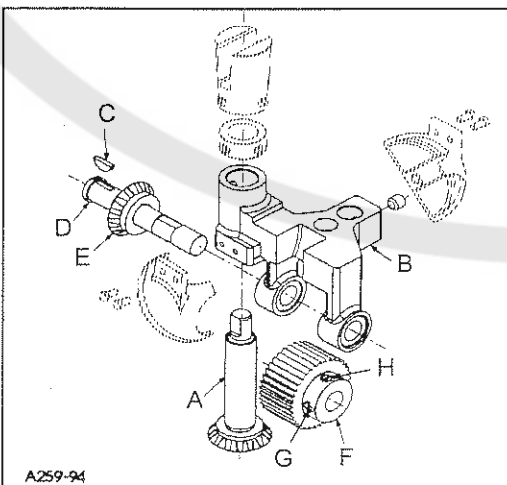

FIG. 16

### Adjusting or Replacing Presser Foot:

Remove presser bar leaf spring (B, Fig. 14) and nut (B). Loosen screw (A, Fig. 15) on presser bar guide (B). Loosen screws (C) in upper collar and screws (D) in needle lever thread pull-off lever. Slide presser bar upward high enough to slip on presser foot yoke (E) with foot attached and tighten screw (F) on flat of presser bar. Position foot so that the needle holes in the foot line up with the holes in the throat plate. Tighten screw (A)

Presser foot guide plates (G, Fig. 15) should be set so that entire presser foot and bar assembly has free movement up and down with no left to right movement.

With foot properly aligned on throat plate and presser bar guide (B, Fig. 15) securely fastened to presser bar, adjust both guide plates (G) to obtain above setting. Tighten four screws (H).

Reinstall presser bar spring (B, Fig. 14) and knob (A), with presser foot resting on throat plate.

Set upper stop collar (K) to contact casting, so the bottom of the needle head and the top of the presser foot do not touch, at the bottom of the needle stroke when lifting foot. Tighten screw (C).

The presser foot should be adjusted to be 1/8" (3.17mm) above the throat plate before the feed roller mechanism begins to rise. Loosen screw (A, Fig. 15) in presser bar lifter and guide (B), raise or lower guide as required to attain the specified point at which the feed roller begins to rise. Retighten screw (A) and maintain needle settings.

NOTE: There should be a minimum 1/32" (0.8mm) clearance between screw (M, Fig. 15) and the bottom of the slot in link (J).

Regulate the pressure on the presser foot by turning the presser spring regulating knob (A, Fig. 14) located on top of pressure foot spring (B).

To remove just the presser foot, remove screws (L, Fig. 15) and replace foot, retighten screws (L).

Needle lever thread pull-off (P) should be set 1/16" (1.6mm) above bottom of slot in cover (Q) when presser foot is resting on throat plate.

### UPPER FEED ROLLER ADJUSTMENT

#### Assembly of Roller to Roller Yoke:

Assemble driven gear (A, Fig. 16) through feed roller frame (B). Place woodruff key (C) into slot of feed roller shaft (D). Slide driven gear (E) on to shaft (D), make sure key (C) goes into slot in gear (E). While holding feed roller frame (B) with steel roller (F) between the two frame lobes, slide feed roller shaft (D) and assembled components through frame. Make sure that shoulder of roller (F) is to the right. Align screw (G) (first in operating direction on roller) on the flat of shaft (E). At the same time thrust shoulder of shaft (D) against face of gear (E), make sure left edge of roller is against right (inside) face of left lobe. Secure screw (G) on flat of shaft (D) and tighten screw (H).



## UPPER FEED ROLLER ADJUSTMENT (CONT.)

When feed roller mechanism (C, Fig. 17) has been removed or replaced, .003" (0.08mm) minimum to .005" (0.13mm) maximum clearance should be maintained between roller and throat plate.

### To Adjust Guiding System for Roller:

Loosen two screws (A). Using shim(s) adjust feed roller mechanism (C) so that the roller is .003" (0.08mm) to .005" (0.13mm) above throat plate. Slide rear guide finger (B) down so that it sits on top of rear guide support block (D). Check to make sure roller is parallel to throat plate slots. Tighten two screws (A) to secure feed roller mechanism in place.

### Setting Pressure for Feed Roller:

Regulate the pressure on the feed roller so that it exerts only enough pressure on the fabric to feed the work uniformly. Turning roller presser spring regulator (H, Fig. 17) clockwise to increase or counterclockwise to decrease the pressure.

### Setting of Feed Roller:

Guide finger for roller should be set so that entire roller mechanism has free movement up and down with no left to right movement. With roller properly aligned, the edge of roller should be parallel with feed slots in throat plate.

Guide plates (F) must be thrust against guide finger (B) to secure feed roller mechanism (C). Thrust guide plates (F) against guide finger (B) with equal pressure. Tighten four screws (E) to hold plates in place.

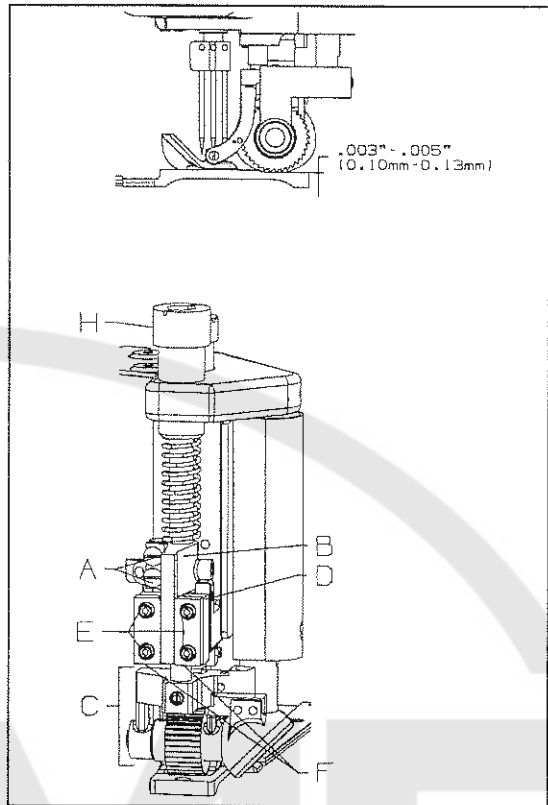

FIG. 17

## THREAD TENSION AND RELEASE

The thread tension release is set correctly when it begins to function at the point when the upper feed roller begins to rise. When adjustment is necessary, loosen screw (B, Fig. 18) in lifter lever (C). Facing the tension release shaft (A) from the right end of the machine, insert screwdriver in slot in shaft (A). Turn the screwdriver clockwise to raise pins (D) or counterclockwise to lower pins. Retighten screw (B).

## DIFFERENTIAL CONTROL

The amount of differential is controlled by lever (A, Fig. 19). The adjusting plate is numbered from 1 to 9. When the lever is set from numbers 1 to 4 reverse differential or stretching occurs. The numbers from 4 to 5 produce equal feed stitching while numbers 5 to 9 produce a gathering stitch. Screws (B) can be set to limit the movement of lever (A) or lock lever in one position. If top ply of material is coming out long, move lever toward operator, if top ply is short, move lever away from operator, as required.

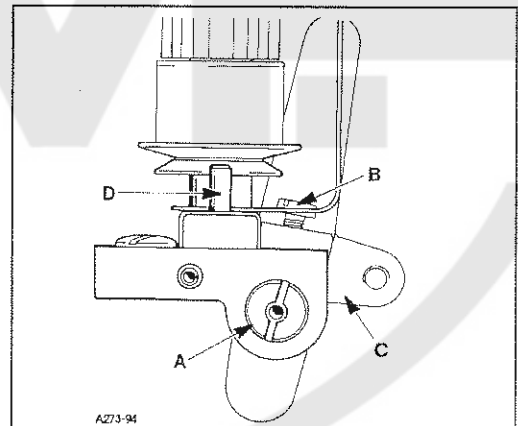

FIG. 18

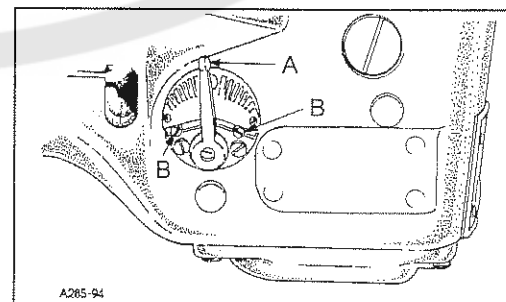

FIG. 19

## SETTING NEEDLE THREAD TAKE-UP AND FRAME EYELET

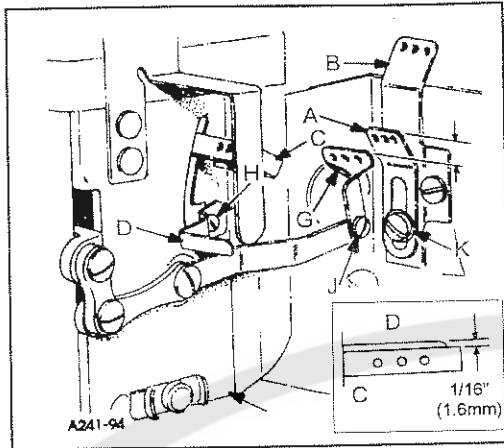

FIG. 20

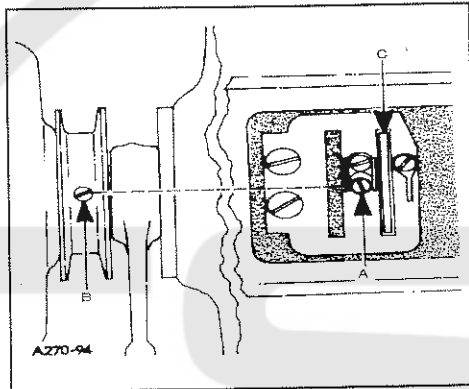

FIG. 21

With the needle bar at the top of its stroke set the adjustable frame needle thread eyelet (A, Fig. 20) in the lower mounting hole of eyelet (B) so the needle thread from eyelet (A) to the needle lever thread eyelet (C) will be in a straight line. If adjustment of eyelet (A) is necessary loosen screw (K) and move eyelet up or down as required. Retighten screw (K).

With the needle bar at the bottom of its stroke, the needle thread take-up (D) should be set so that it is  $1/16$ " (1.6mm) above the edge of the needle lever thread eyelet (C) (See Inset). If adjustment is necessary loosen screw (H) and adjust lever (D) as required to attain  $1/16$ ". Tighten screw (H).

## LOOPER THREAD TAKE-UP ADJUSTMENT

With the machine rotating in operating direction the looper thread take-up is in time when the first screw coming into view (A, Fig. 21) is in line with the spot screw (B) on the main shaft in the pulley. NOTE: screw (A) is accessible through the hole in the take-up. With this setting correct, the looper thread should cast-off of the take-up (C) when the needles are safely in the triangle. If adjustment is necessary loosen two screws (A) in take-up (C) position screws in line with spot screw (B). Tighten screws (A).

NOTE: Make sure take-up cam is centered left to right in cast-off slot.

## FOLDER ADJUSTMENT

Slide folder (A, Fig. 22) on arm. The folder should be as close to the front of presser foot (B) as possible, making sure to avoid the presser foot contacting the folder when sewing across seams. If adjustment is necessary loosen screws (C) to move entire folder left to right or front to back as required. If just adjustment of upper scroll (D) is needed loosen screw (E) and position scroll to obtain proper seam margin.

## AIR BLOWER TUBE ADJUSTMENT

The air blower tube should be set left to right so it is parallel with the throat plate. It should be set front to back so when feeding over a cross seam the presser foot does not contact the tube. If adjustment is necessary, loosen screw (A, Fig. 23) and position air blower tube (B) as required. Retighten screw (A).

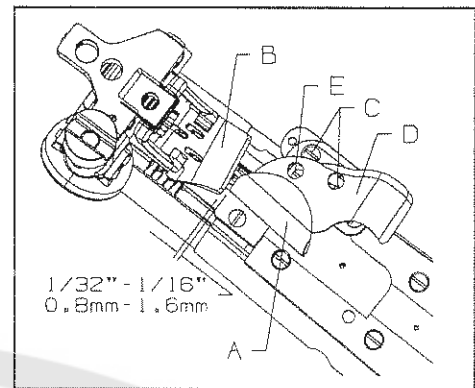

FIG. 22

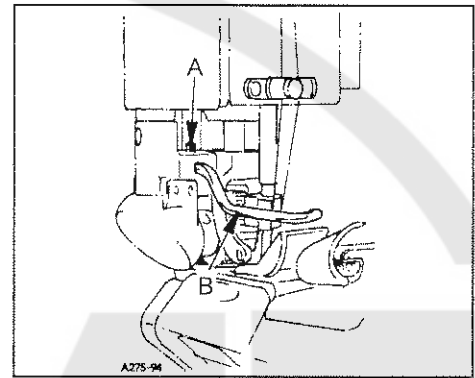
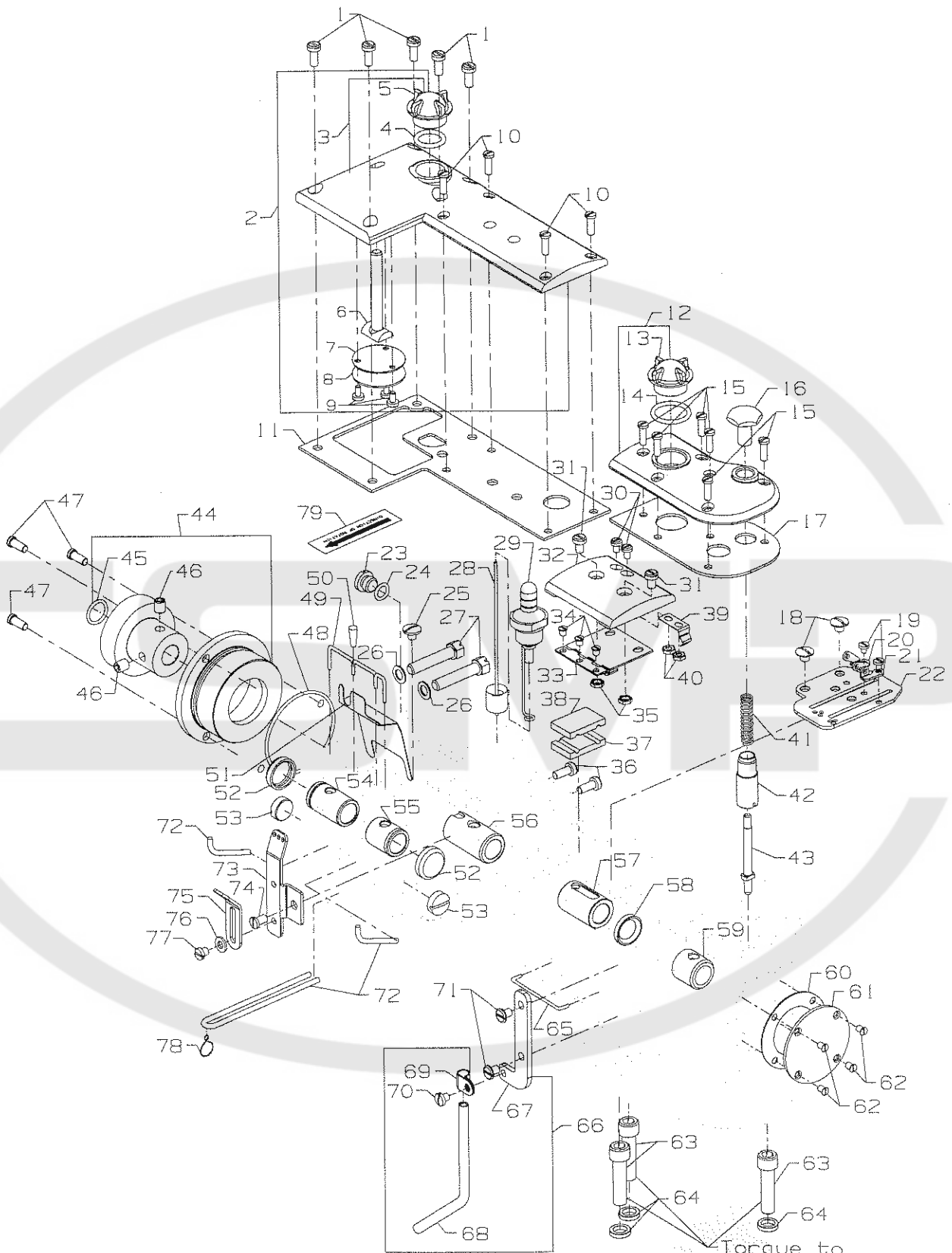

FIG. 23





MAIN FRAME, CAST-OFF PLATE, EYELETS, MISCELLANEOUS COVERS AND BUSHINGS

Ref. No.	Part No.	Description	Amt. Req.
1.	93	Screw .....	5
2.	29476XK	Chamber Cover Assembly .....	1
3.	35882NR	Crank Chamber Cover .....	1
4.	660-212	"O" Ring .....	1
5.	22924708	Oil Sight Gauge .....	1
6.	35878F	Presser Spring .....	1
7.	35888M	Gasket .....	1
8.	35888L	Cover Plate .....	1
9.	98A	Screw .....	3
10.	22516A	Screw .....	4
11.	35888T	Gasket .....	1
12.	35887AE	Top Cover, front .....	1
13.	22924708	Oil Sight Gauge .....	1
14.	660-212	"O" Ring .....	1
15.	22516A	Screw .....	6
16.	35853Z	Looper Throw-Out Plunger Knob .....	1
17.	35887AG	Gasket .....	1
18.	22730	Screw .....	2
19.	28	Screw .....	2
20.	35772S	Cast-Off Plate Eyelet .....	1
21.	35772T	Cast-Off Plate Eyelet .....	1
22.	35704C	Cast-Off Plate .....	1
23.	22733B	Oil Drain Screw .....	1
24.	660-206	"O" Ring .....	1
25.	22711	Screw, for oil wick .....	1
26.	6042A	Washer .....	2
27.	22759A	Screw .....	2
28.	36293F	Oil Sight Gauge Indicator Assembly .....	1
29.	36293B	Oil Sight Gauge .....	1
30.	90	Screw .....	2
31.	93A	Screw .....	2
32.	35887X	Top Cover, middle .....	1
33.	35887R	Middle Top Cover Hinge .....	1
34.	22564B	Screw .....	3
35.	12934A	Nut .....	2
36.	93	Screw, for rotary pump housing .....	2
37.	35893H	Seal, Lower .....	1
38.	35893G	Seal, Upper .....	1
39.	35887M	Spring, top cover .....	1
40.	41071G	Nut .....	2
41.	35853Y	Looper Throw-Out Plunger Spring .....	1
42.	35853AA	Looper Throw-Out Bushing .....	1

43. thru 79. See following page.



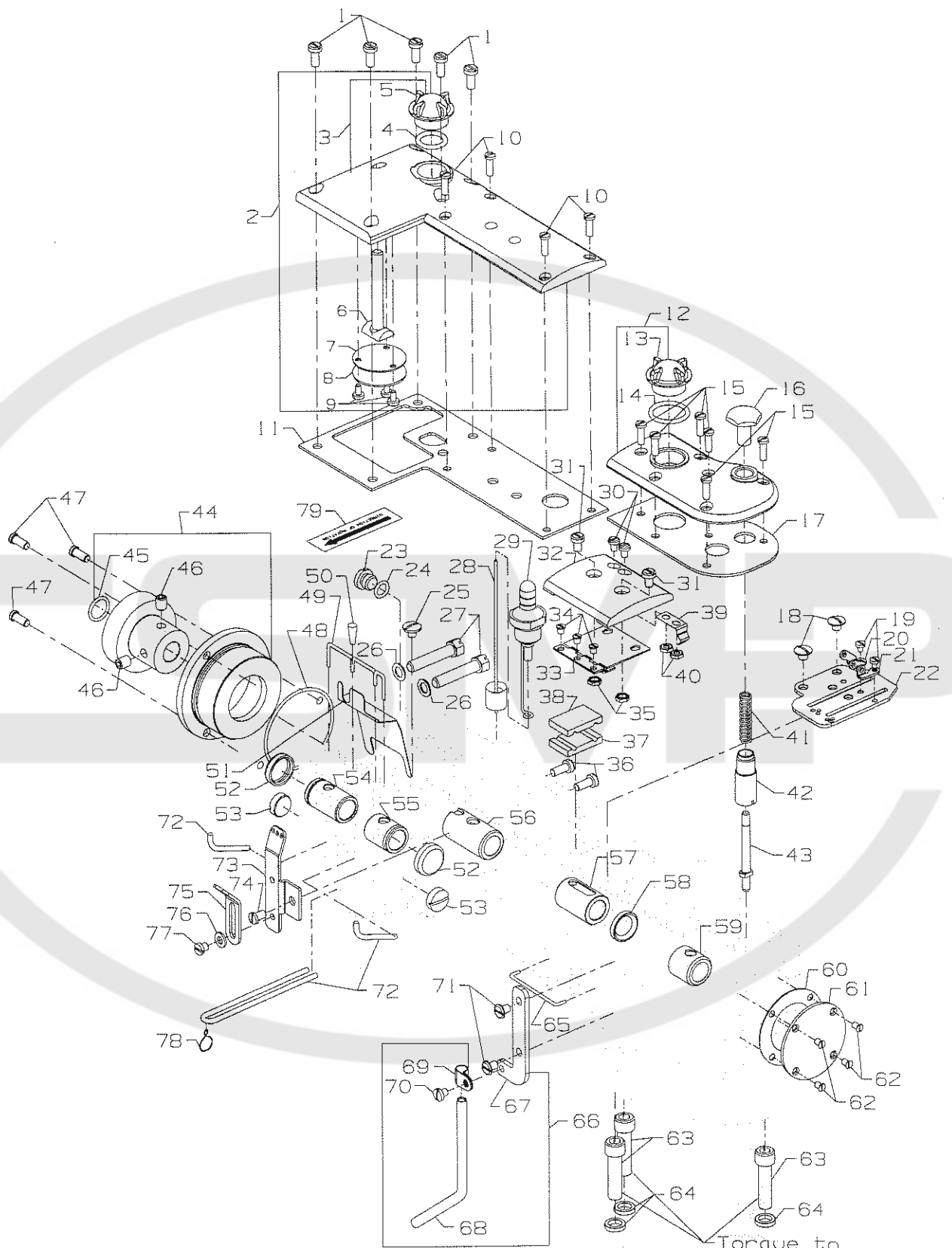

Torque to  
18 ft. lbs.



MAIN FRAME, CAST-OFF PLATE, EYELETS, MISCELLANEOUS COVERS AND BUSHINGS (CONT.)

Ref. No.	Part No.	Description	Amt. Req.
1. thru 42. See preceding page.			
43.	35853W	Looper Throw-Out Plunger .....	1
44.	35890M	Bearing Housing Assembly .....	1
45.	660-1014	"O" Ring .....	1
46.	22894F	Screw .....	2
47.	22569B	Screw .....	3
48.	660-935	"O" Ring .....	1
49.	CL21	Oil Wick .....	1
50.	C067E	Cork .....	1
51.	35889H	Oil Shield .....	1
52.	35761D	Bushing Cap, plastic .....	2
53.	22539T	Plug Screw .....	2
54.	35760E	Needle Lever Shaft Bushing, rear .....	1
55.	35760D	Needle Lever Shaft Bushing, front .....	1
56.	35890E	Crankshaft Bushing, front .....	1
57.	35890Q	Mainshaft Bushing, rear .....	1
58.	660-1132	Oil Seal .....	1
59.	36290B	Mainshaft Bushing, front .....	1
60.	35881AF	Gasket .....	1
61.	35887Z	Mainframe End Cover .....	1
62.	22766	Screw .....	4
63.	22653E-24	Screw .....	3
64.	35876U	Washer .....	3
65.	35871D	Looper Thread Guide Wire .....	1
66.	29105BH	Looper Thread Tube Assembly, for differential feed .....	1
-	29105BL	Looper Thread Tube Assembly, for plain feed (not shown) .....	1
67.	35883AL	Support .....	1
68.	35866A	Tube, for differential feed .....	1
69.	35866C	Tube, for plain feed (not shown) .....	1
-	35866B	Clamp, tube .....	1
70.	SS7110510SP	Screw .....	1
71.	22829	Screw .....	2
72.	CL21	Oil Wick .....	1
73.	35871B	Needle Thread Eyelet, three holes .....	1
74.	22570A	Screw .....	1
75.	35871A	Needle Thread Eyelet, three holes .....	1
76.	8372A	Washer .....	1
77.	22570	Screw .....	1
78.	35897CK	Oil Wick Hook, upper .....	1
79.	LA527	Label .....	1



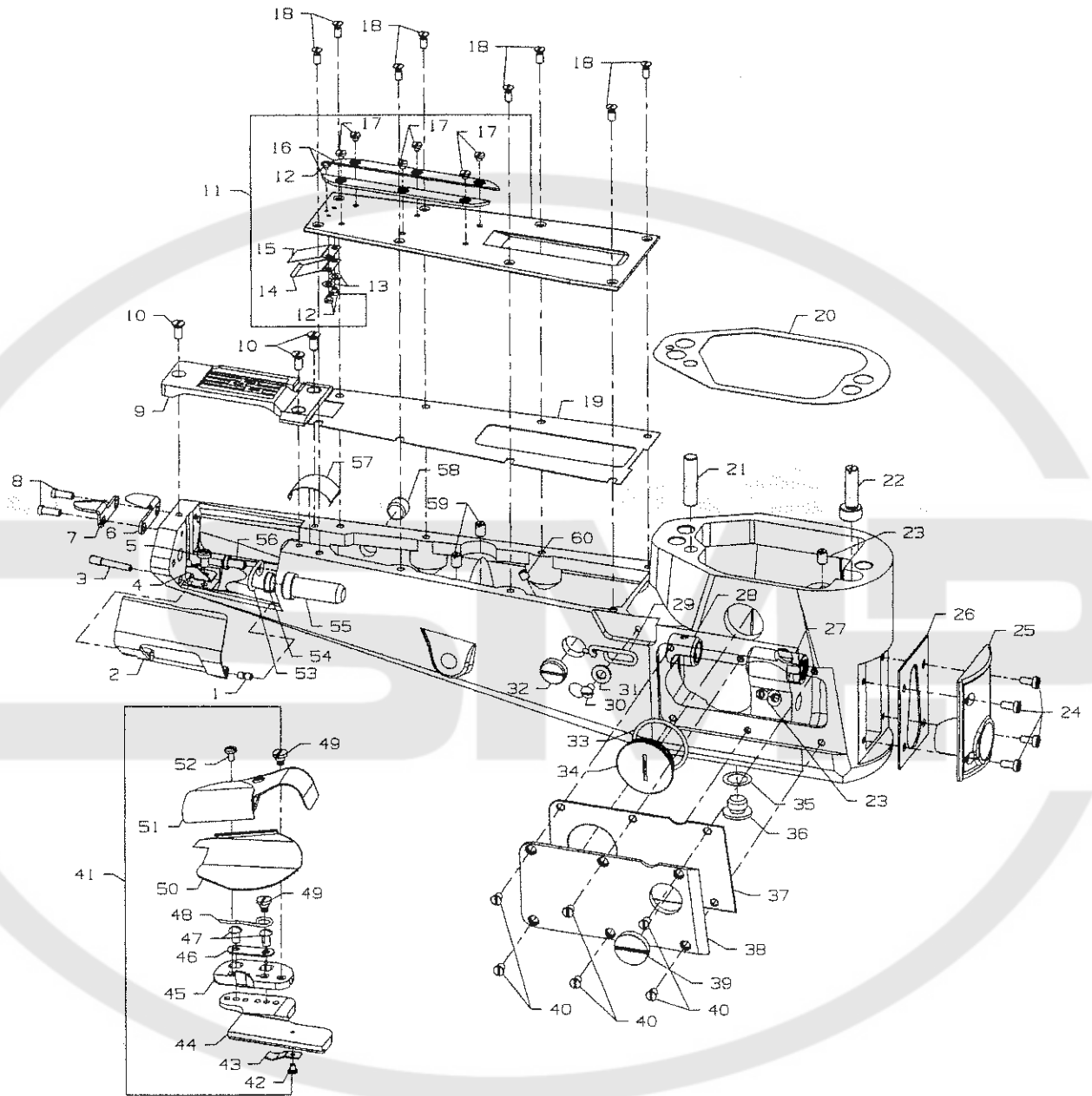

## FOLDER, CYLINDER COVERS AND BUSHINGS FOR PLAIN FEED

Ref. No.	Part No.	Description	Amt. Req.
1.	35883G	Pin .....	1
2.	35883H	Cylinder Hinged Cover .....	1
3.	22791E	Screw Pin .....	1
4.	35883E	Spring .....	1
5.	90	Screw .....	1
6.	35796C	Chain Cutter Blade, lower .....	1
7.	35796B	Chain Cutter Blade, upper .....	1
8.	22747	Screw .....	2
9.	-----	Throat Plate (see page 51) .....	1
10.	22524	Screw, for all throat plates .....	3
11.	35883A	Cylinder Cover .....	1
12.	22798	Screw .....	3
13.	27-435BLK	Washer .....	2
14.	35884E	Cylinder Lint Shield, upper .....	1
15.	35884F	Cylinder Lint Shield Spring .....	1
16.	35883J	Cylinder Cover Adjustable Gib .....	2
17.	22561A	Screw .....	6
18.	22526B	Screw .....	8
19.	36284	Gasket .....	1
20.	35883M	Gasket .....	1
21.	667D-16	Dowel Pin, straight .....	1
22.	36229A1	Eccentric Pin .....	1
23.	531	Screw .....	2
24.	J87J	Screw .....	4
25.	35884H	Cylinder Cover and Oil Gauge .....	1
26.	35884R	Gasket .....	1
27.	35850C	Looper Shaft Bushing, front .....	1
28.	35850B	Looper Shaft Bushing, Middle .....	1
29.	51758	Looper Thread Eyelet .....	1
30.	22849A	Screw .....	1

31. thru 60. See following page.



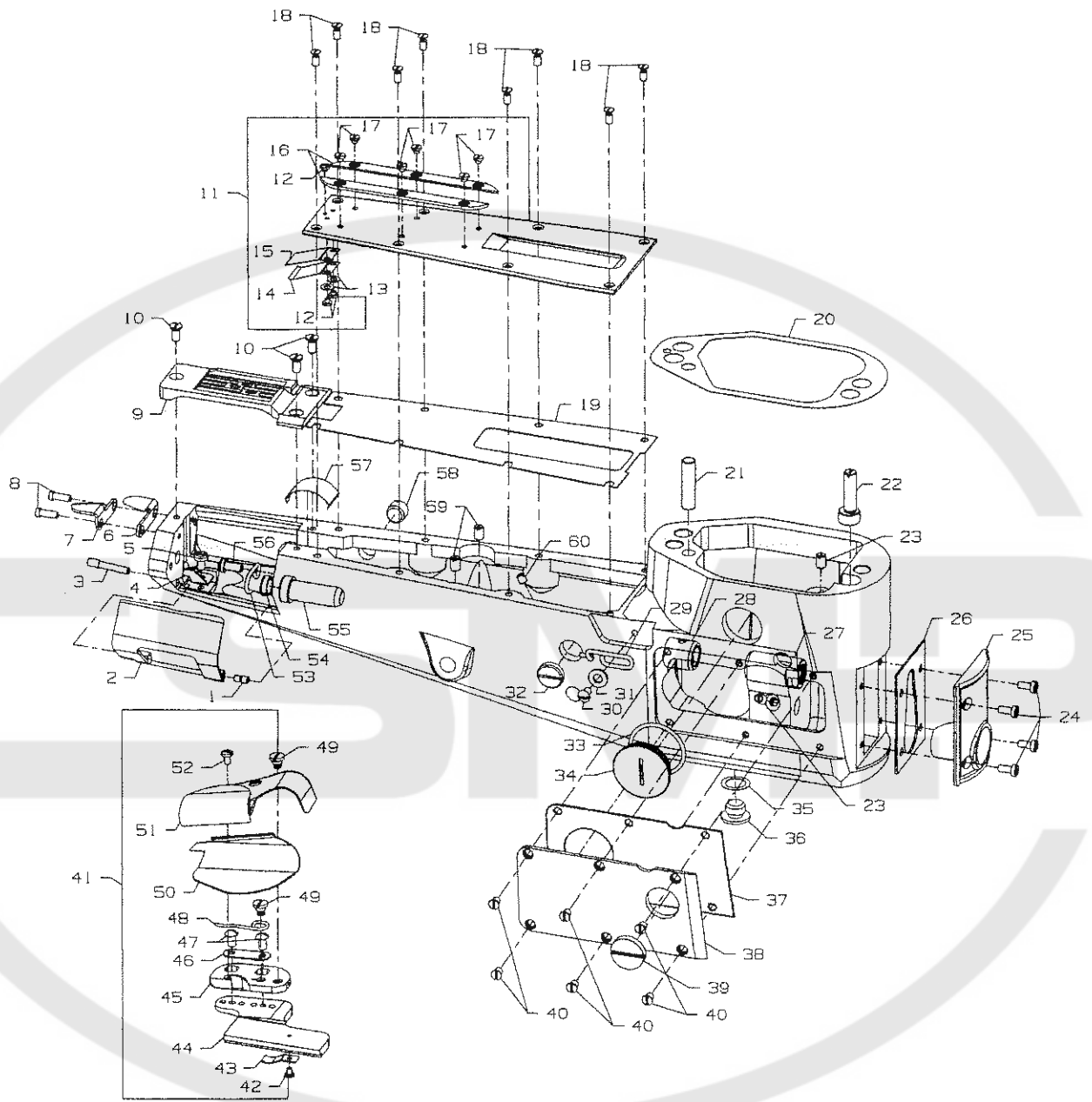

FOLDER, CYLINDER COVERS AND BUSHINGS FOR PLAIN FEED (CONT.)

Ref. No.	Part No.	Description	Amt. Req.
1. thru 30. See preceding page.			
31.	8372A	Washer .....	1
32.	22539H	Plug Screw .....	1
33.	660-1115	"O"Ring .....	1
34.	22539AL	Plug Screw .....	1
35.	35897AX	Gasket .....	1
36.	22733A	Oil Drain Plug Screw .....	1
37.	35886B	Gasket .....	1
38.	35886C	Cylinder Side Cover .....	1
39.	22539C	Plug Screw .....	1
40.	22564B	Screw .....	6
41.	23420AY18-1/8	Folder Assembly, for all Styles .....	1
42.	73A	Screw .....	1
43.	23424F	Folder Support Spring .....	1
44.	23424AA	Folder Support Slide .....	1
45.	23424T	Base .....	1
46.	23425T	Clamp, for sliding base .....	1
47.	22849A	Screw .....	2
48.	23424S	Spring .....	1
49.	22760A	Screw .....	2
50.	23422AY18-1/8	Lower Scroll .....	1
51.	23421Y9-1/8	Upper Scroll .....	1
52.	87U	Screw .....	1
53.	36256B	Looper Thread Guide Wire .....	1
54.	660-1117	Oil Seal for 35850G .....	1
55.	35850G	Looper Shaft Bushing, rear .....	1
56.	22849	Screw .....	1
57.	35884L	Lower Lint Shield .....	1
58.	22571A	Plug Screw .....	1
59.	531	Screw, for feed lifter lever shaft .....	2
60.	88	Screw, for feed rocker shaft .....	1





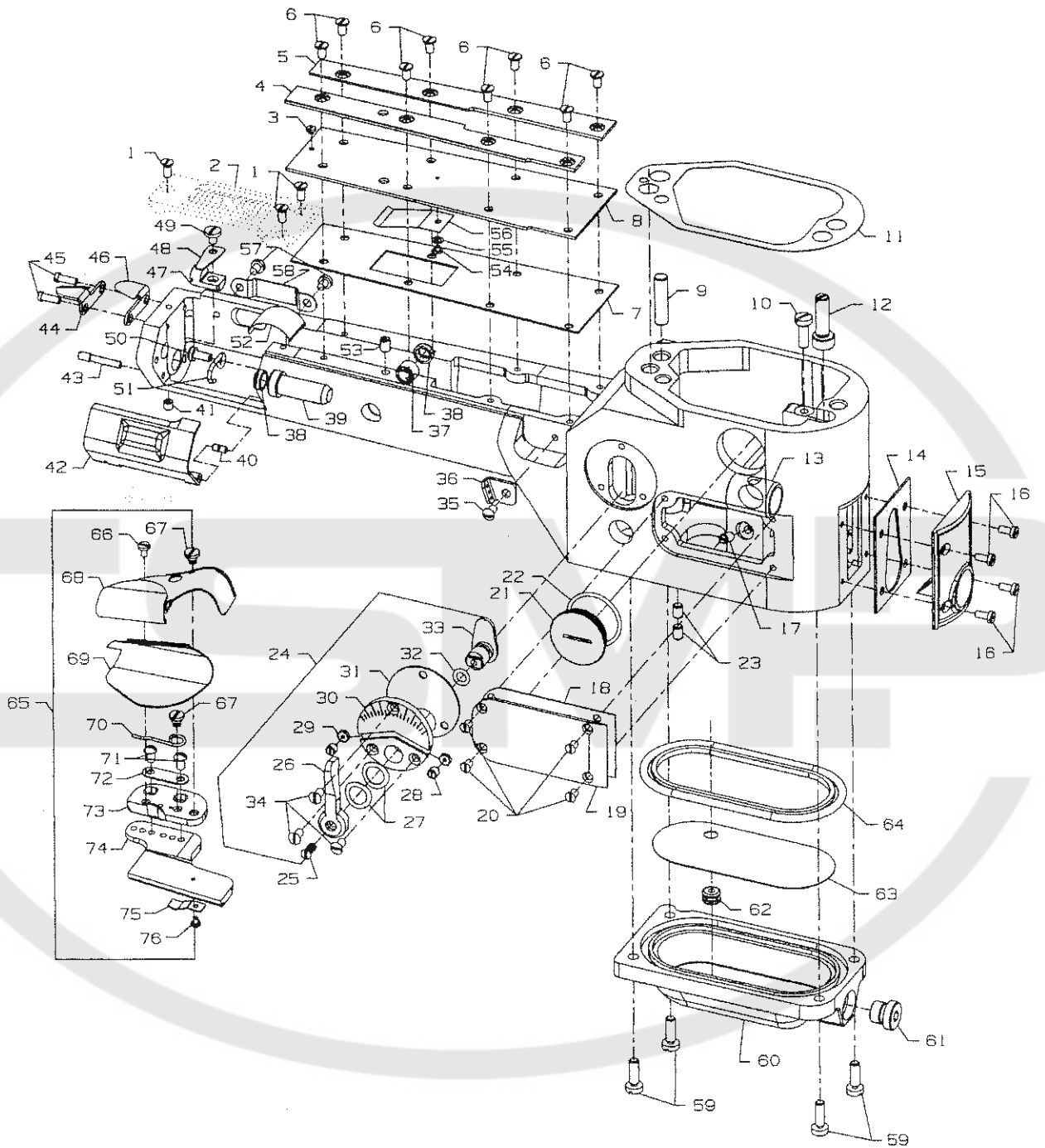

FOLDER, CYLINDER COVERS AND BUSHINGS FOR DIFFERENTIAL FEED

Ref. No.	Part No.	Description	Amt. Req.
1.	22524	Screw .....	3
2.	-----	Throat Plate (see page 51) .....	1
3.	22798	Screw .....	1
4.	35883N	Folder Gib, left .....	1
5.	35883P	Folder Gib, right .....	1
6.	22564J	Screw .....	8
7.	35883AA	Gasket .....	1
8.	35883T	Cylinder Cover .....	1
9.	667D-16	Dowel Pin, straight .....	1
10.	22596	Screw .....	1
11.	36284	Gasket .....	1
12.	36229A-1	Eccentric Stud .....	1
13.	36249A	Looper Shaft Bushing, front .....	1
14.	35884R	Gasket .....	1
15.	36284C	Cylinder Cover and Oil Gauge, front .....	1
16.	J87J	Screw .....	4
17.	22560A	Screw .....	1
18.	36286B	Gasket .....	1
19.	36286	Cylinder Side Cover .....	1
20.	22766	Screw .....	4
21.	22539AL	Plug Screw .....	1
22.	660-1115	"O" Ring .....	1
23.	531	Screw .....	2
24.	29478CZ	Differential Feed Control Assembly .....	1
25.	538	Screw .....	1
26.	36237K	Operating Lever .....	1
27.	36237J	Spring Washer .....	2
28.	36237H	Stop Screw Pin .....	2
29.	60078Z	Nut .....	2
30.	36238	Adjusting Plate .....	1
31.	36238E	Gasket .....	1
32.	660-220	Oil Seal Ring .....	1
33.	36237E	Adjusting Lever .....	1
34.	87A	Screw .....	3
35.	22849A	Screw .....	1
36.	35856Y	Looper Thread Eyelet .....	1

37. thru 76. See following page.



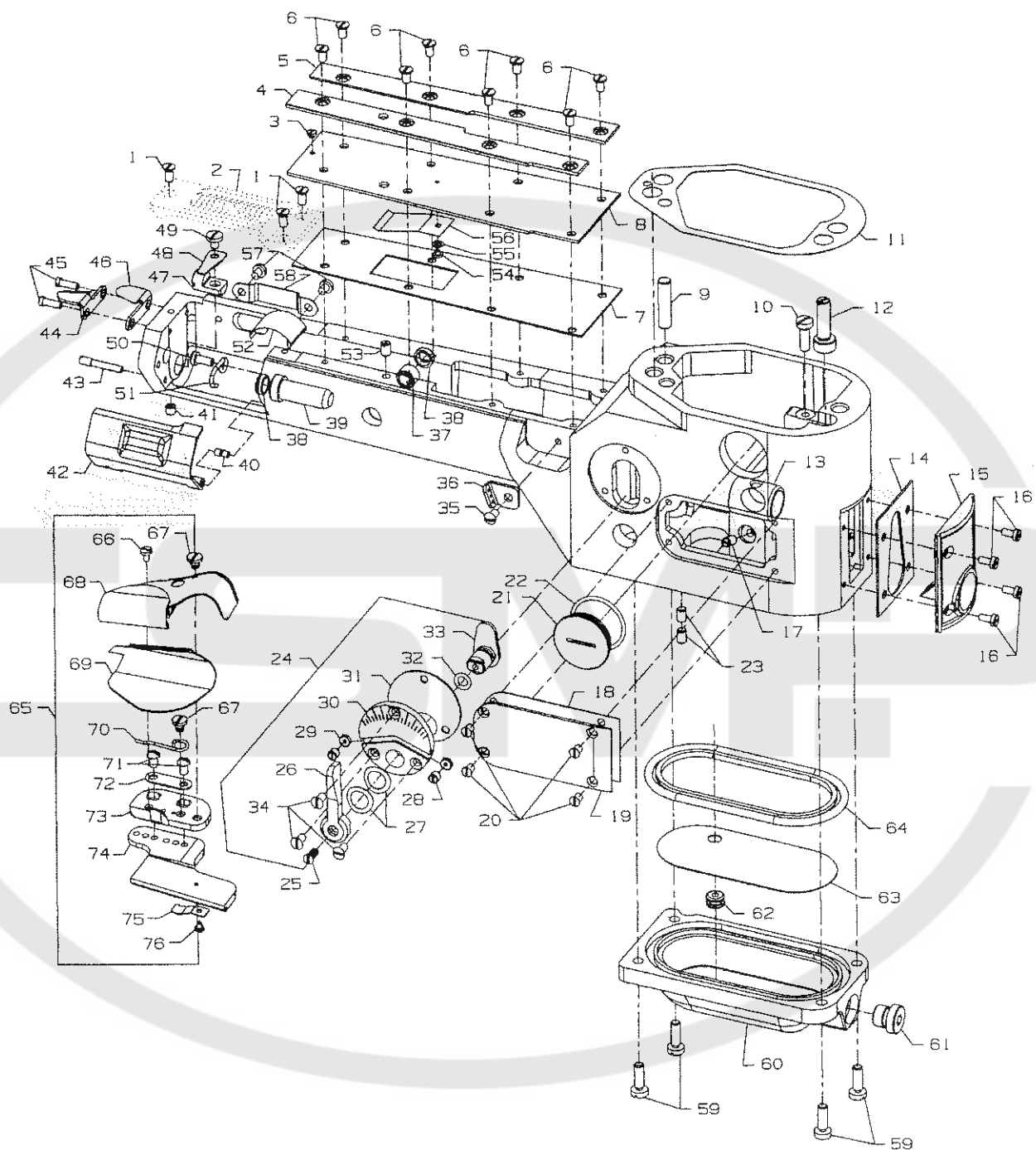

FOLDER, CYLINDER COVERS AND BUSHINGS FOR DIFFERENTIAL FEED (CONT.)

Ref. No.	Part No.	Description	Amt. Req.
1. thru 36. See preceding page.			
37.	36237L	Bushing, for feed bar eccentric stud .....	1
38.	660-1117	Oil Seal .....	2
39.	35850G	Looper Shaft Bushing, rear .....	1
40.	35883G	Pin .....	1
41.	22894W	Screw, for cylinder hinge cover spring support stud .....	1
42.	35883R	Cylinder Hinged Cover .....	1
43.	22791E	Screw Pin .....	1
44.	35796B	Chain Cutter Blade, upper .....	1
45.	22747	Screw .....	2
46.	35796C	Chain Cutter Blade, lower .....	1
47.	36283C	Cylinder Hinged Cover Spring Support Stud .....	1
48.	35883U	Cylinder Cover Spring .....	1
49.	22585C	Screw .....	1
50.	22849	Screw .....	1
51.	36256B	Cylinder Looper Thread Guide Wire .....	1
52.	35884K	Lower Lint Shield .....	1
53.	531	Screw .....	1
54.	22798	Screw .....	1
55.	27-435BLK	Washer .....	1
56.	36284E	Upper Lint Shield .....	1
57.	22513D	Screw .....	2
58.	35896B	Cylinder Guard, for Looper .....	1
59.	22596	Screw .....	4
60.	36282	Bottom Cover .....	1
61.	999-196	Screw .....	1
62.	661-150	"O" Ring .....	1
63.	36293G	Screen .....	1
64.	36284F	Gasket .....	1
65.	23420AY18-1/8	Folder Assembly, for 35800DNU, DRU, DRW, DWW, PZ, DZ .....	1
-	23420AY18-3/32	Folder Assembly, for 35800DLU .....	1
66.	87U	Screw .....	1
67.	22760A	Screw .....	2
68.	23421Y9-1/8	Upper Scroll and Base, for 23420AY-1/8 Folder .....	1
-	23421Y9-3/32	Upper Scroll and Base, for 23420AY-3/32 Folder .....	1
69.	23422AY18-1/8	Lower Scroll, for 23420AY-1/8 Folder .....	1
-	23422AY18-3/32	Lower Scroll, for 23420AY-3/32 Folder .....	1
70.	23424S	Lower Scroll Spring .....	1
71.	22849A	Screw .....	2
72.	23425T	Clamp Plate .....	1
73.	23424T	Base .....	1
74.	23424AA	Folder Support Slide .....	1
75.	23424F	Folder Support Spring .....	1
76.	73A	Screw .....	1



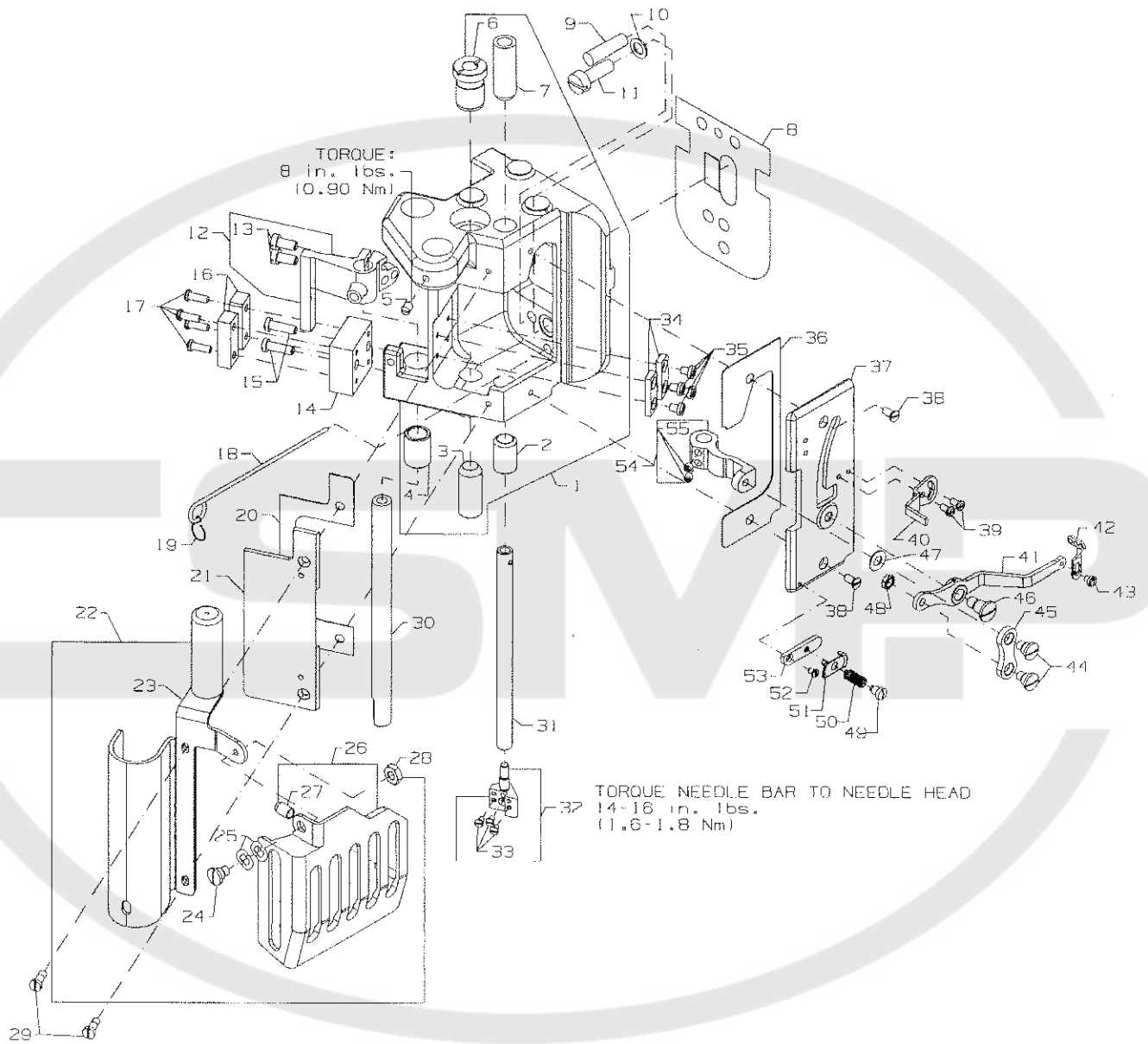

## DETACHABLE HEAD ASSEMBLY

Ref. No.	Part No.	Description	Amt. Req.
1.	35829AP	Detachable Head Assembly .....	1
2.	35854B	Lower Needle Bar Bushing .....	1
3.	35844N	Presser Bar Bushing .....	1
4.	35844T	Bushing .....	1
5.	SS8120740SP	Set Screw .....	1
6.	35878H	Presser Bar Bushing .....	1
7.	35854A	Upper Needle Bar Bushing .....	1
8.	35889G	Plate, baffle .....	1
9.	664F-16	Pin, taper .....	1
10.	6042A	Washer .....	1
11.	318	Screw .....	1
12.	35837P	Guide Finger, rear .....	1
13.	SS6121010SP	Screw .....	2
14.	35838B	Block, support, rear guide .....	1
15.	SS7121410TP	Screw .....	2
16.	35838A	Plate, guide, roller bar .....	2
17.	SS4091015SP	Screw .....	4
18.	CL21	Oil wick .....	1
19.	35897CK	Oil wicking hook .....	1
20.	35884S	Gasket .....	1
21.	35882J	Cover, head, left .....	1
22.	29476YR	Sewing Guard Assembly .....	1
23.	35882T	Puller Drive Cover Assembly .....	1
24.	22758E	Screw .....	1
25.	WZ0641510KP	Spring Washer .....	2
26.	35896D	Sewing Guard .....	1
27.	666-340A	Bumper Plug .....	1
28.	9937	Nut .....	1
29.	22594	Screw .....	2
30.	35887AM	Roller Presser Bar .....	1
31.	35817S	Needle Bar .....	1
32.	35818CB-8	Needle Head (8 gauge) .....	1
-	35818CB-9	Needle Head (9 gauge) .....	1
33.	605	Screw .....	3
34.	35731A	Plate, guide, presser bar .....	2
35.	22513D	Screw .....	4
36.	35884T	Gasket .....	1
37.	35882K	Cover, head, front .....	1
38.	22524	Screw .....	2
39.	22768	Screw .....	2
40.	35870	Take-Up, needle thread .....	1
41.	35869C	Needle Thread Control Lever .....	1
42.	35869K	Needle Thread Control Lever Eyelet .....	1
43.	25B	Screw .....	1
44.	22758E	Screw .....	2
45.	35869D	Control Lever Connection Link .....	1
46.	22557A	Screw .....	1
47.	20	Washer .....	2
48.	12934A	Nut .....	1
49.	57WD	Screw .....	1
50.	15438C	Spring .....	1
51.	57WB	Nipper Plate, needle thread .....	1
52.	605	Screw .....	1
53.	43296	Needle Thread Nipper Base .....	1
54.	35869L	Thread Controller Arm .....	1
55.	89	Screw .....	2



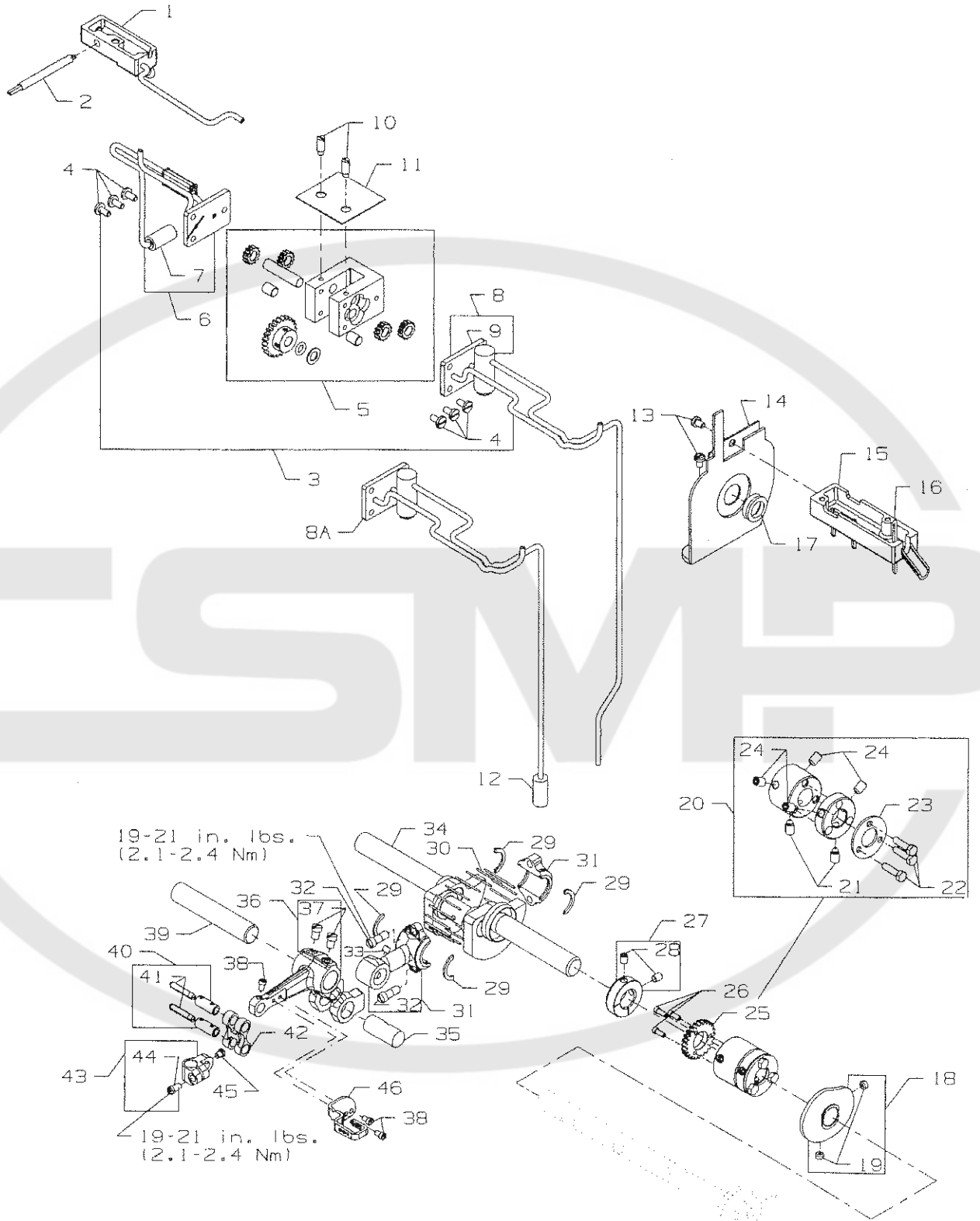

## OILING, NEEDLE LEVER, CRANKSHAFT AND MAIN SHAFT PARTS

Ref. No.	Part No.	Description	Amt. Req.
1.	35894V	Oil Reservoir, back .....	1
2.	35897BU	Oil Reservoir Outlet Tube .....	1
3.	29472AD	Oil Pump Assembly for 35800DLU, DNU, DWW, DZ .....	1
-	29472AA	Oil Pump Assembly for 35800DRU, DRW, PZ .....	1
4.	22585A	Screw .....	6
5.	29472AC	Oil Pump Assembly .....	1
6.	35897CC	Oil Pump Assembly Cover, rear .....	1
7.	35897BV	Intake Filter .....	1
8.	35897CH	Oil Pump Housing Cover, front for 35800DLU, DNU, DWW, DZ .....	1
8A.	35897BM	Oil Pump Housing Cover, front for 35800DRU, DRW, PZ .....	1
9.	22571B	Plug Screw .....	1
10.	21756G	Vent Screw, for oil pump .....	2
11.	35897BW	Gasket .....	1
12.	35897BV	Oil filter for 35800DRU, DRW, PZ .....	1
13.	90	Screw .....	2
14.	36261A	Take-Up Shield Assembly .....	1
15.	35894K	Oil Reservoir, front .....	1
16.	WO3	Oil Wick .....	1
17.	666-338	Oil Seal Ring .....	1
18.	35723C	Looper Thread Take-Up .....	1
19.	22580D	Screw .....	2
20.	35895W	Mainshaft and Crankshaft Coupling .....	1
21.	22894K	Spot Screw .....	2
22.	22519F	Screw .....	3
23.	35895Z	Washer Plate .....	1
24.	22894J	Set Screw .....	4
25.	35897BY	Oil Pump Driving Gear .....	1
26.	22797	Screw .....	3
27.	35895Y	Collar .....	1
28.	22894AM	Screw .....	2
29.	35763G	Needle Bearing Retainer .....	4
30.	35763F	Needle Bearing .....	28
31.	35862A	Needle Lever Connecting Rod .....	1
32.	22587B	Screw .....	2
33.	22894W	Screw .....	1
34.	35822W	Crankshaft .....	1
35.	35847X	Needle Lever Connecting Rod Pin .....	1
36.	35815C	Needle Lever .....	1
37.	22596B	Screw .....	2
38.	77	Screw .....	1
39.	35761	Needle Lever Shaft .....	1
40.	51054A	Link Pin .....	2
41.	666-149	Oil Wick .....	2
42.	56354D	Needle Lever Link .....	1
43.	35816	Needle Bar Connection .....	1
44.	SS7111120TP	Screw .....	1
45.	22564	Screw .....	1
46.	35864F	Needle Lever Thread Eyelet .....	1





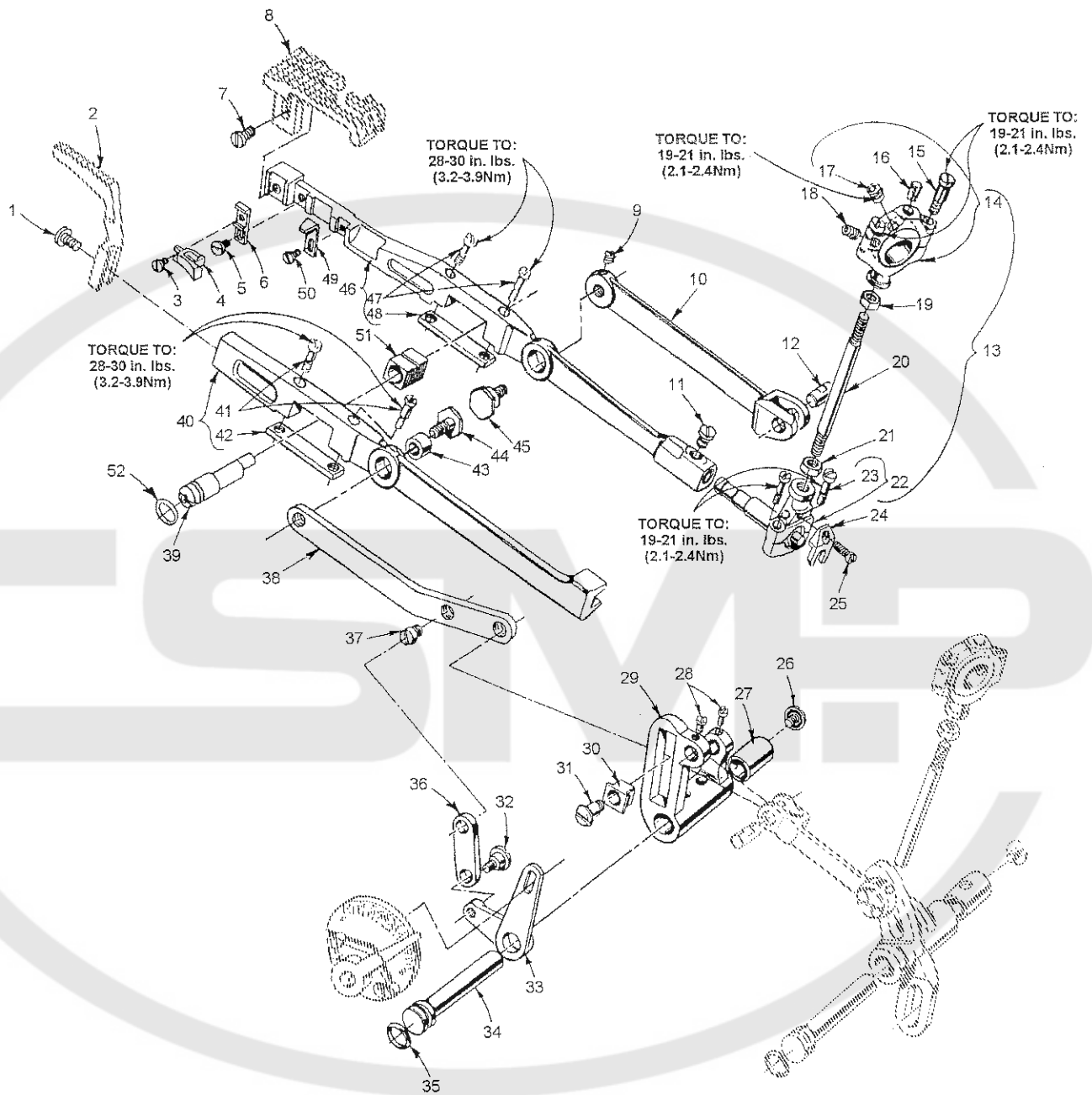

P161-94



DIFFERENTIAL FEED BAR, MAIN FEED BAR, FEED LIFT ECCENTRIC ASSEMBLY  
FOR DIFFERENTIAL FEED

Ref. No.	Part No.	Description	Amt. Req.
1.	22528	Screw .....	1
2.	-----	Differential Feed Dog (see page 51) .....	1
3.	87U	Screw .....	1
4.	35825AC	Needle Guard .....	1
5.	22768	Screw .....	1
6.	35835B	Needle Guard Holder .....	1
7.	22528	Screw .....	1
8.	-----	Main Feed Dog (see page 51) .....	1
9.	22894P	Screw .....	1
10.	35834W	Main Feed Bar Driving Link .....	1
11.	33174B	Screw .....	1
12.	62238A	Link Pin .....	1
13.	29478DV	Feed Lift Eccentric Assembly, for styles 35800DLU, DNU, DZ .....	1
-	29478EB	Feed Lift Eccentric Assembly, for style 35800DWW .....	1
14.	29103T	Feed Lift Eccentric Assembly Ball Joint, for 29478DV .....	1
-	29103U	Feed Lift Eccentric Assembly Ball Joint, for 29478EB .....	1
15.	22587E	Screw .....	2
16.	WO3	Oil Wick .....	1
17.	22894W	Set Screw .....	2
18.	22894AA	Spot Screw .....	1
19.	269	Nut, left thread .....	1
20.	36244	Connecting Rod .....	1
21.	18	Nut, right thread .....	1
22.	36244A	Ball Joint, complete .....	1
23.	22729C	Screw .....	2
24.	41255B	Ball Fork .....	1
25.	22747	Screw .....	1
26.	22733G	Screw .....	1
27.	36236B	Bushing, for feed rocker shaft .....	1
28.	77	Screw .....	2
29.	35836A	Feed Rocker .....	1
30.	36236K	Differential Feed Driving Link Slide Block .....	1
31.	36236J	Differential Feed Bar Driving Link Stud .....	1
32.	22504C	Screw .....	1
33.	36237	Differential Feed Adjusting Lever .....	1
34.	36236A	Feed Rocker Shaft .....	1
35.	660-220	"O"Ring .....	1
36.	36237A	Differential Feed Adjusting Lever Link .....	1
37.	22845M	Screw .....	1
38.	35836L	Differential Feed Bar Driving Link .....	1
39.	36234M	Feed Bar Eccentric Stud .....	1
40.	36234F	Differential Feed Bar .....	1
41.	22587H	Screw .....	2
42.	36234G	Feed Bar Plate .....	1
43.	36236H	Bushing .....	1
44.	36236G	Differential Feed Bar Driving Link Stud .....	1
45.	35834X	Main Feed Bar Eccentric Driving Stud .....	1
46.	35834AB	Main Feed Bar .....	1
47.	22587H	Screw .....	2
48.	36234G	Feed Bar Plate .....	1
49.	35834AC	Main Feed Dog Support .....	1
50.	22804	Screw .....	1
51.	36234C	Feed Bar Slide Block .....	1
52.	660-220	"O"Ring .....	1



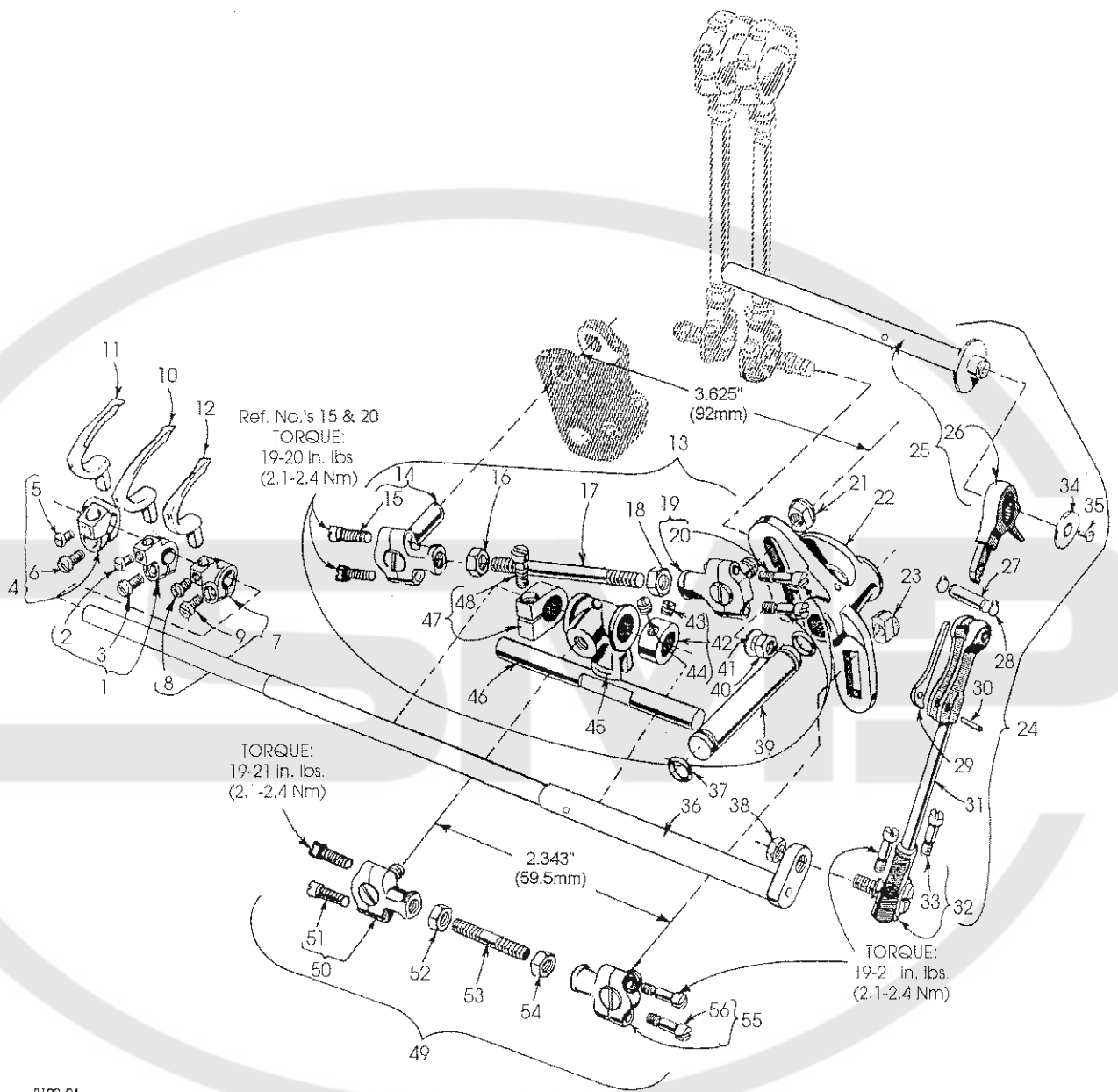

P190-94



FEED DRIVE COMPONENTS, LOOPER DRIVE COMPONENTS AND LOOPERS  
FOR PLAIN FEED

Ref. No.	Part No.	Description	Amt. Req.
1.	35848E	Looper Holder, for middle looper, marked "D" .....	1
2.	22564	Screw .....	1
3.	22562A	Screw .....	1
4.	35848D	Looper Holder, for left looper, marked "C" .....	1
5.	22562A	Screw .....	1
6.	22564	Screw .....	1
7.	35848B	Looper Holder, for right looper, marked "A" .....	1
8.	22562A	Screw .....	1
9.	22564	Screw .....	1
10.	35809AY	Looper, middle, marked "AV" .....	1
11.	35809BY	Looper, left, marked "AY" .....	1
12.	35808AY	Looper, right, marked "AU" .....	1
13.	29478AH	Feed Rocker Connecting Rod Assembly .....	1
14.	35837A	Ball Joint .....	1
15.	22729C	Screw .....	2
16.	18	Nut, right thread .....	1
17.	39141	Connecting Rod .....	1
18.	269	Nut, left thread .....	1
19.	35837N	Ball Joint .....	1
20.	22729C	Screw .....	2
21.	35866	Nut .....	1
22.	35842	Feed Rocker and Looper Avoid Lever .....	1
23.	35766A	Nut .....	1
24.	29478DZ	Looper Drive Connecting Rod Assembly .....	1
25.	35722AF	Main Shaft Assembly .....	1
26.	35853AJ	Looper Drive Connection .....	1
27.	35853V156	Hinge Pin .....	1
28.	660-310	Tru-Arc Ring .....	2
29.	56341G	Locking Spring .....	1
30.	50-458BLK	Pin .....	1
31.	35853AK	Looper Drive Connecting Rod .....	1
32.	35853AD	Ball Joint, looper shaft .....	1
33.	22729D	Screw .....	2
34.	35895V	Washer .....	1
35.	22526	Screw .....	1
36.	35849B	Feed Rocker and Looper Lever Shaft .....	1
37.	660-220	Oil Seal Ring .....	2
38.	258A	Nut .....	1
39.	35842H	Looper Rocker Shaft .....	1
40.	258A	Nut .....	1
41.	6042A	Washer .....	1
42.	35751F	Looper Shaft Collar .....	1
43.	88	Screw .....	1
44.	89	Screw .....	1
45.	35751	Looper Rocker Shaft Cross Head .....	1
46.	35751B	Cross Head Guide Shaft .....	1
47.	35751G	Thrust Collar .....	1
48.	22752B	Screw .....	1
49.	29478AJ	Connecting Rod Assembly .....	1
50.	35851A	Ball Joint .....	1
51.	22729C	Screw .....	2
52.	18	Nut, right thread .....	1
53.	35851G	Connecting Rod .....	1
54.	269	Nut, left thread .....	1
55.	35851	Ball Joint .....	1
56.	22729C	Screw .....	2



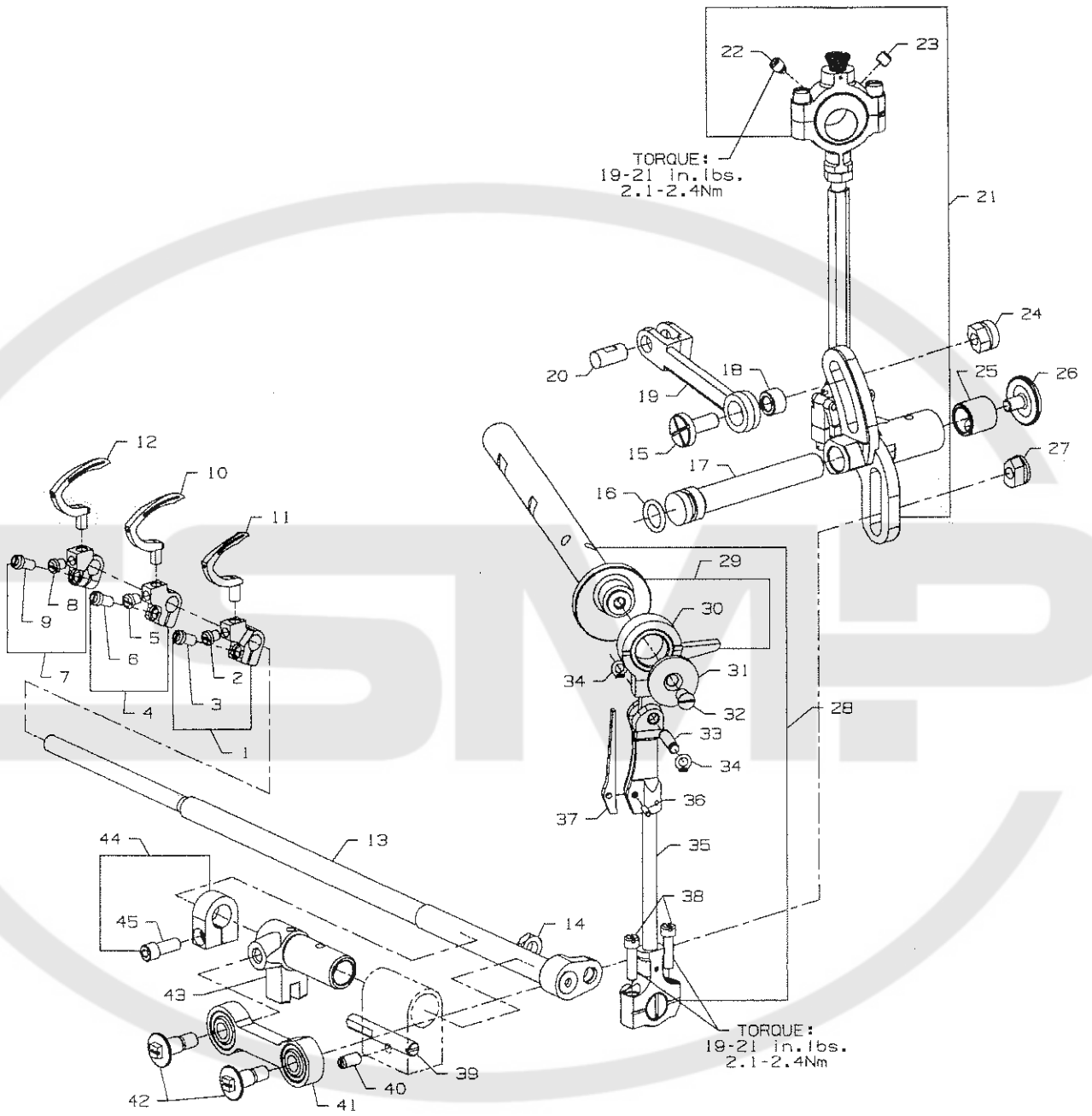

LOOPERS, LOOPER HOLDERS, FEED DRIVE COMPONENTS AND LOOPER AVOID  
COMPONENTS FOR DIFFERENTIAL FEED

Ref. No.	Part No.	Description	Amt. Req.
1.	35848B	Looper Holder, for Right looper, marked "A" .....	1
2.	22564	Screw .....	1
3.	22562A	Screw .....	1
4.	35848E	Looper Holder, for Middle looper, marked "D" .....	1
5.	22564	Screw .....	1
6.	22562A	Screw .....	1
7.	35848D	Looper Holder, for Left looper, marked "C" .....	1
8.	22564	Screw .....	1
9.	22562A	Screw .....	1
10.	35809AY	Looper, middle, marked "AV" .....	1
11.	35808AY	Looper, right, marked "AU" .....	1
12.	35809BY	Looper, left, marked "AY" .....	1
13.	35849C	Looper Rocker Shaft .....	1
14.	258A	Nut .....	1
15.	35836C	Feed Rocker Driving Link Screw .....	1
16.	660-207	Oil Seal Ring .....	1
17.	36236A	Feed Drive Shaft .....	1
18.	36236H	Bushing, for feed rocker driving link .....	1
19.	36236C	Feed Rocker Driving Link .....	1
20.	62238A	Link Pin .....	1
21.	29478EC	Feed Drive Assembly .....	1
22.	22894W	Screw .....	1
23.	22894U	Screw .....	1
24.	35866	Nut .....	1
25.	36236B	Bushing .....	1
26.	22733G	Screw .....	1
27.	35766B	Nut .....	1
28.	29478DZ	Looper Drive Connecting Rod Assembly .....	1
29.	35722AF	Main Shaft Complete .....	1
30.	35853AJ	Looper Drive Connection .....	1
31.	35895V	Shaft Stop Washer .....	1
32.	22526	Screw .....	1
33.	35853V156	Hinge Pin .....	1
34.	660-310	Truarc Ring .....	2
35.	35853AK	Looper Drive Connecting Rod .....	1
36.	50-458BLK	Pin .....	1
37.	56341G	Locking Spring .....	1
38.	22729C	Screw .....	2
39.	36278C	Stud, For Looper Shaft Sleeve .....	1
40.	22560A	Screw .....	1
*41.	35851S	Connecting Rod Bearing Shell .....	1
*42.	35851P	Screw .....	1
43.	36249B	Looper Shaft Sleeve .....	1
44.	35751G	Looper Shaft Collar .....	1
45.	22752B	Screw .....	1

\* For older style machines these parts  
must be purchased as assembly 29478FI



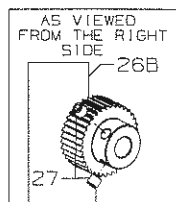
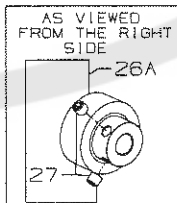
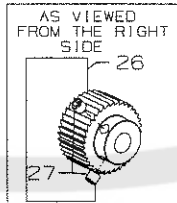
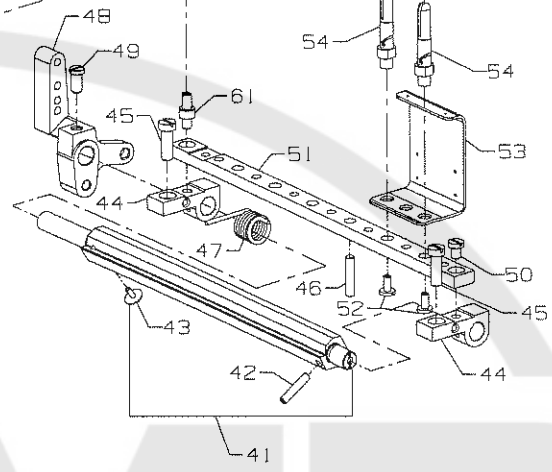
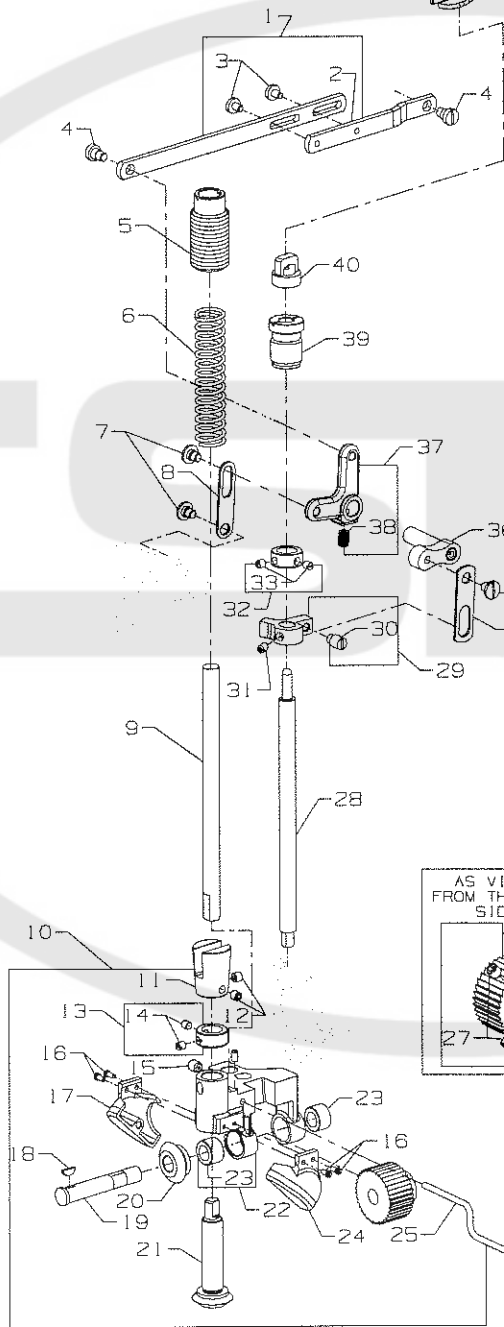
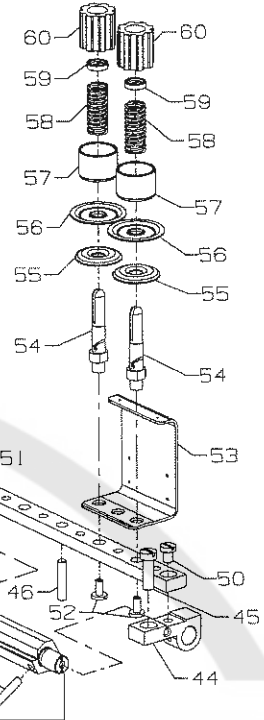
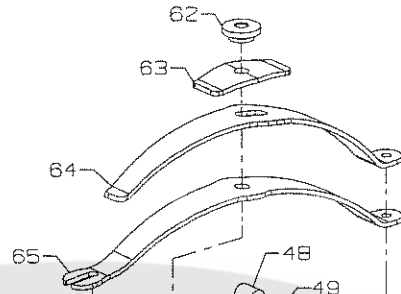
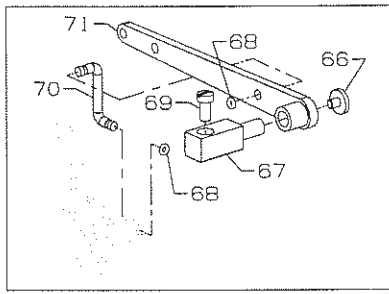

## UPPER ROLLER FEED, FOOT LIFTER AND THREAD TENSION PARTS

Ref. No.	Part No.	Description	Amt. Req.
1.	36280V	Lifter Lever Link Assembly .....	1
2.	36280U	Lifter Lever Link .....	1
3.	22585C	Screw .....	2
4.	86	Screw .....	2
5.	35892A	Puller Bar Knob, rear .....	1
6.	50377L	Spring, puller bar .....	1
7.	22758C	Screw .....	2
8.	35835F	Lifter Lever Bell Crank Link .....	1
9.	35877AM	Roller Presser Bar .....	1
10.	29478EN	Puller Assembly, for styles 35800DNU, DRU (see chart) .....	1
-	29478ED	Puller Assembly, for style 35800DRW, DWW (see chart) .....	1
-	29478FL	Puller Assembly, for style 35800DLU (see chart) .....	1
-	K74401	Puller Assembly, reverse teeth roller for styles 35800PZ, DZ (see chart) .....	1
11.	54274C	Feed Roller Lower Connection .....	1
12.	22894W	Screw .....	2
13.	14649	Drive Gear Collar .....	1
14.	88	Screw .....	2
15.	22894C	Screw .....	1
16.	22738	Screw .....	4
17.	35875Z	Gear guard, rear .....	1
18.	35877AA	Woodruff Key .....	1
19.	35873AK	Feed Roller Shaft .....	1
20.	35875X	Driven Miter Gear .....	1
21.	35875Y	Drive Miter Gear .....	1
22.	35873AJ	Feed Roller Frame .....	1
23.	660-303	Needle Bearing .....	2
24.	35875AA	Gear Guard, front .....	1
25.	21237ES	Air Blower Tube .....	1
26.	35875AV	Feed Roller, steel (.468 wide) for 29478EN (see chart) .....	1
-	35826X	Feed Roller, steel (.588 wide) for 29478ED (see chart) .....	1
26A.	35826EF	Feed Roller, rubber (.468 wide) (see chart) .....	1
-	35826DZ	Feed Roller, rubber (.588 wide) (see chart) .....	1
26B.	35875AW	Feed Roller, reverse teeth (.468 wide) for K74401 (see chart) .....	1
-	35826CB	Feed Roller, reverse teeth (.588 wide) (see chart) .....	1
27.	22894W	Screw .....	2
28.	35878S	Presser Bar .....	1
29.	35831C	Presser Bar Lifter and Guide .....	1
30.	402	Screw .....	1
31.	22560B	Screw .....	1
32.	52888B	Collar .....	1
33.	22562	Screw .....	2
34.	35880L	Lifter Lever Connecting Link .....	1

35. thru 71. See following page.

PULLER ASSEMBLY	FEED ROLLER					
	35875AV	35826X	35826EF	35826DZ	35826AW	35826CB
29478EN	STANDARD		EXTRA SEND AND CHARGE		EXTRA SEND AND CHARGE	
29478ED		STANDARD		EXTRA SEND AND CHARGE		EXTRA SEND AND CHARGE
29478FL	EXTRA SEND AND CHARGE		STANDARD		EXTRA SEND AND CHARGE	
K74401	EXTRA SEND AND CHARGE		EXTRA SEND AND CHARGE		STANDARD	





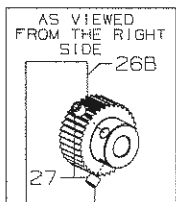
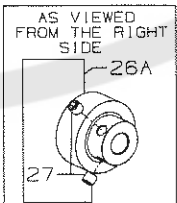
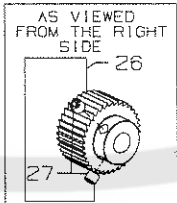
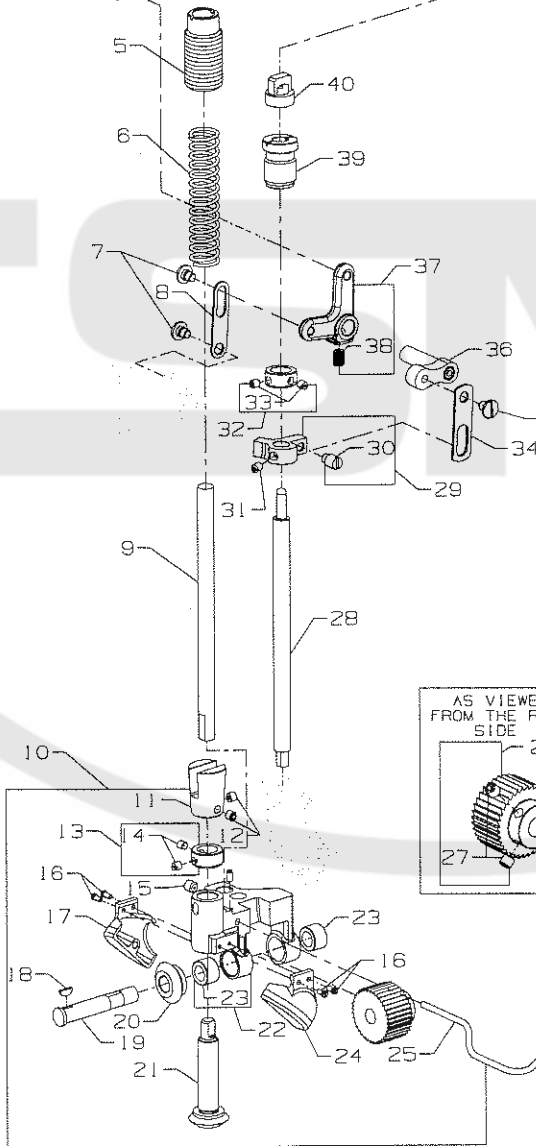
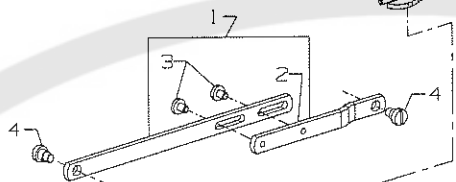
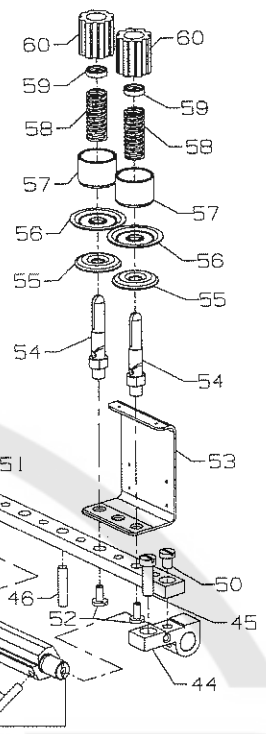
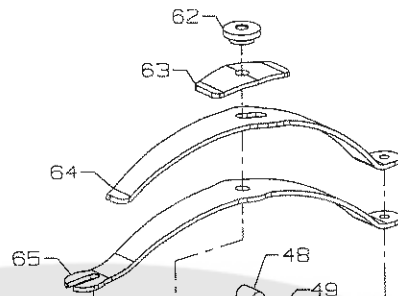
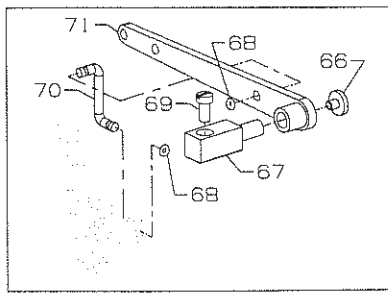

UPPER ROLLER FEED, FOOT LIFTER AND THREAD TENSION PARTS (CONT.)

Ref. No.	Part No.	Description	Amt. Req.
1. thru 34. See preceding page.			
35.	22758C	Screw .....	1
36.	35880N	Presser Bar Lifter Lever .....	1
37.	35880P	Lifter Lever Bell Crank .....	1
38.	22894J	Screw .....	1
39.	35878H	Presser Bar Spring and Regulator .....	1
40.	55287L	Presser Bar Knob .....	1
41.	36292N	Tension Release Shaft .....	1
42.	660-219S	Pin .....	1
43.	22784F	Screw .....	1
44.	36292M	Tension Plate Bracket .....	2
45.	136	Screw .....	2
46.	35792T	Tension Disc Release Pin .....	7
47.	36292K	Tension Release Shaft Spring .....	1
48.	36280W	Lifter Lever .....	1
49.	22839D	Screw .....	1
50.	94	Screw .....	1
51.	36298H	Tension Support .....	1
52.	22585A	Screw .....	6
53.	36298G	Tension Thread Eyelet .....	3
54.	36292Q	Tension Post .....	6
55.	109	Tension Disc, small .....	6
56.	35792	Tension Disc, large .....	6
57.	W56392F	Shield, tension spring .....	6
58.	51292F4	Looper Thread Tension Spring, for looper .....	3
-	110-3	Needle Thread Tension Spring, for needle .....	3
59.	39592AK	Tension Post Ferrule .....	6
60.	WC50092S	Tension Nut .....	6
61.	35833F	Presser Spring Rest .....	1
62.	35733B	Presser Regulating Screw .....	1
63.	35833C	Presser Spring Plate .....	1
64.	35833E	Presser Spring, Upper .....	1
65.	35833D	Presser Spring, Lower .....	1
66.	255	Screw .....	1
67.	36280N	Presser Foot Lifter Bearing Bracket .....	1
68.	660-254C	Retaining Ring .....	2
69.	22517	Screw .....	1
70.	36280T	Lifter Lever Connecting Link .....	1
71.	36280S	Presser Foot Connecting Lifter Lever .....	1



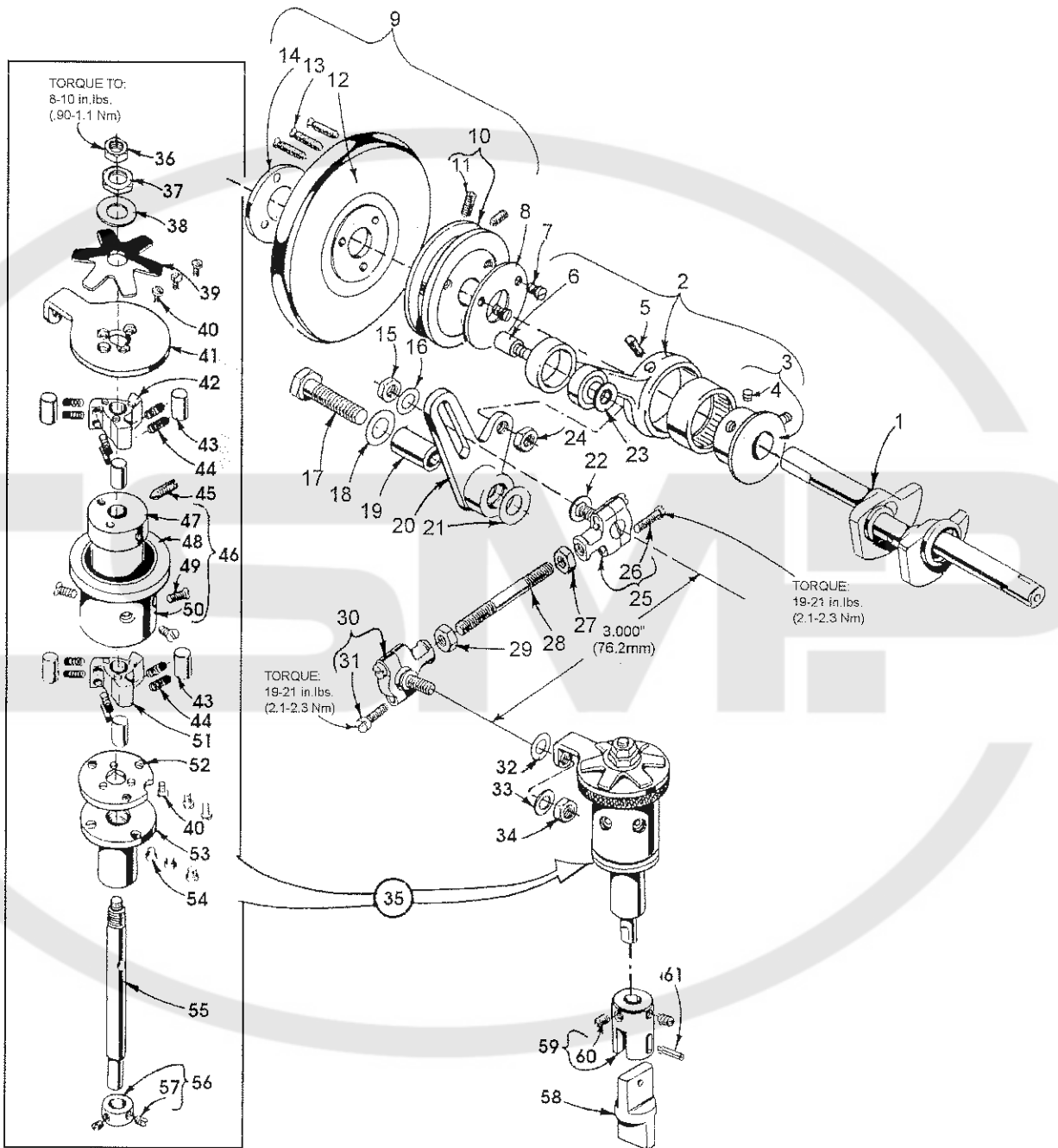

P185-94



PULLEY, CRANKSHAFT, CLUTCH AND CLUTCH DRIVING MECHANISM

Ref. No.	Part No.	Description	Amt. Req.
1.	35822W	CrankShaft .....	1
2.	29480ALY	Connecting Rod and Clutch Driving Eccentric Assembly .....	1
3.	35877XA	Eccentric .....	1
4.	22894C	Screw .....	2
5.	666-186	Oil Wick .....	1
6.	50342V	Shoulder Screw .....	1
7.	22589	Screw .....	3
8.	35821V	Washer .....	1
9.	35821S	Pulley Assembly .....	1
10.	35821X	Pulley .....	1
11.	22894E	Set Screw .....	2
12.	61321J	Handwheel .....	1
13.	22574	Screw .....	3
14.	61321L	Clamp Plate .....	1
15.	258	Nut .....	1
16.	20	Washer .....	1
17.	22644K-80	Screw .....	1
18.	61351C	Washer .....	1
19.	35877N	Segment Lever Bushing .....	1
20.	35877Z	Clutch Driving Segment Lever .....	1
21.	61351C	Washer .....	1
22.	36G	Washer .....	1
23.	6042A	Washer .....	1
24.	258	Nut .....	1
25.	35876V	Ball Joint Assembly, right .....	1
26.	22729C	Screw .....	2
27.	269	Nut, left hand thread .....	1
28.	4761	Roller Clutch Connecting Rod .....	1
29.	18	Nut, right hand thread .....	1
30.	35876W	Roller Clutch Ball Joint Assembly, left .....	2
31.	22729C	Screw .....	2
32.	80557	Washer .....	1
33.	20	Washer .....	1

34. thru 62. See following page



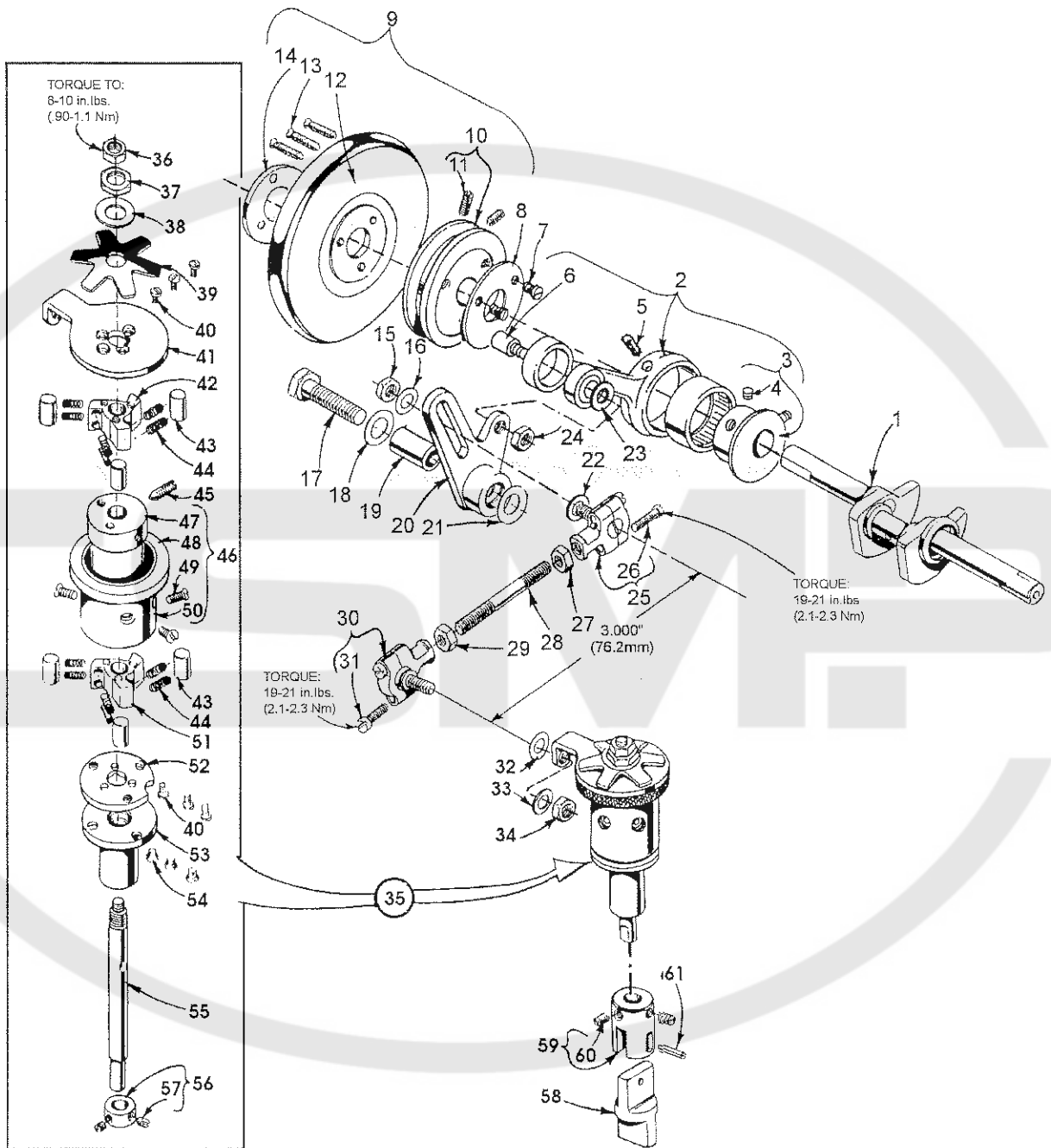

P165-94



PULLEY, CRANKSHAFT, CLUTCH AND CLUTCH DRIVING MECHANISM (CONT.)

Ref. No.	Part No.	Description	Amt. Req.
1. thru 33. See preceding page			
34.	18	Nut .....	1
35.	29478BY	Constant Wedge Angle Clutch Assembly .....	1
36.	18	Nut .....	1
37.	11638M	Nut .....	1
38.	61351C	Washer .....	1
39.	54274N	Brake Spring .....	1
40.	605A	Screw .....	6
41.	35876AC	Clutch Drive Lever .....	1
42.	54274H	Clutch Disc, upper .....	1
43.	54274L	Clutch Roller .....	6
44.	54274Y	Clutch Roller Spring and Wear Cap .....	12
45.	22894H	Spot Screw .....	1
46.	35876AB	Barrel Assembly .....	1
47.	50-835BLK	Barrel Core .....	1
48.	35876AD	Drive Lever Brake .....	1
49.	538	Screw .....	3
50.	50-834BLK	Barrel .....	1
51.	54274H	Clutch Disc, lower .....	1
52.	35876AG	Locking Spacer Plate .....	1
53.	35876AF	Lower Bearing .....	1
54.	22564	Screw .....	3
55.	35876AE	Feed Drive Shaft .....	1
56.	41363U	Collar .....	1
57.	22743	Screw .....	2
58.	54279	Feed Roller Drive Floating Connection .....	1
59.	35876AH	Feed Roller Connection, upper .....	1
60.	22560B	Screw .....	2
61.	660-219	Roll Pin .....	1
62.	99622A	Washer .....	1



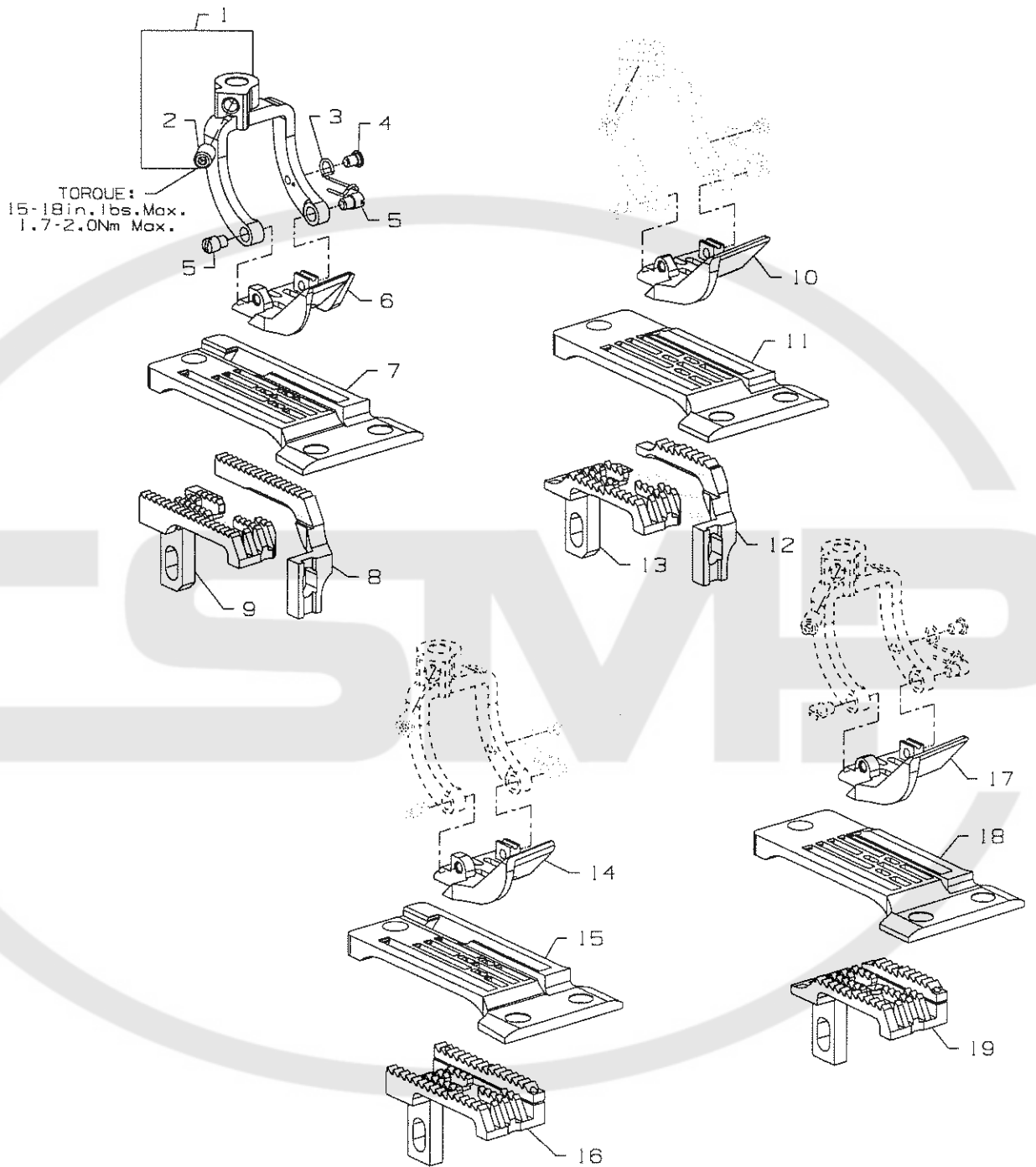

## SEWING PARTS

Ref. No.	Part No.	Description	Amt. Req.
1.	35830DY	Presser Foot Fork .....	1
2.	22894BJ	Screw .....	1
3.	35830K	Spring .....	1
4.	22599	Screw .....	1
5.	22845A	Screw .....	2
6.	35830DL9	Presser Foot, for Style 35800DLU9 .....	1
-	35830DM8	Presser Foot, for Style 35800DNU8, DZ32 .....	1
-	35830DM9	Presser Foot, for Style 35800DNU9 DZ36 .....	1
7.	35824BQ9	Throat Plate, for Style 35800DLU9 .....	1
-	35824DN8	Throat Plate, for Style 35800DNU8 DZ32 .....	1
-	35824DN9	Throat Plate, for Style 35800DNU9 DZ36 .....	1
8.	35826DL	Differential Feed Dog, for style 35800DLU9 .....	1
-	35826DP	Differential Feed Dog, for styles 35800DNU8, DNU9, DZ32, DZ36 .....	1
9.	35805DP8	Main Feed Dog, for Styles 35800DLU9, DNU8, DNU9, DZ32, DZ36 .....	1
10.	35830DWW8	Presser Foot, for Style 35800DWW8 .....	1
-	35830DWW9	Presser Foot, for Style 35800DWW9 .....	1
11.	35824DX8	Throat Plate, for Style 35800DWW8 .....	1
-	35824DX9	Throat Plate, for Style 35800DWW9 .....	1
12.	35805DX	Differential Feed Dog, for styles 35800DWW9 .....	1
13.	35826DX	Main Feed Dog, for Styles 35800DWW8 .....	1
14.	35830BX8	Presser Foot, for 8 gauge styles 35800DRU, PZ32 .....	1
-	35830BX9	Presser Foot, for 9 gauge styles 35800DRU, PZ36 .....	1
15.	35824DQ8	Throat Plate, marked "AG-8", for 8 gauge, styles 35800DRU, PZ32 .....	1
-	35824DQ9	Throat Plate, marked "AG-9", for 9 gauge, styles 35800DRU, PZ36 .....	1
16.	35805BR8	Feed Dog, for 8 and 9 gauge, styles 35800DRU, PZ32, PZ36 .....	1
17.	35830BXW9	Presser Foot, for Style 35800DRW9 .....	1
18.	35824DQW9	Throat Plate, for Style 35800DRW9 .....	1
19.	35805BRW8	Main Feed Dog, for Styles 35800DRW9 .....	1





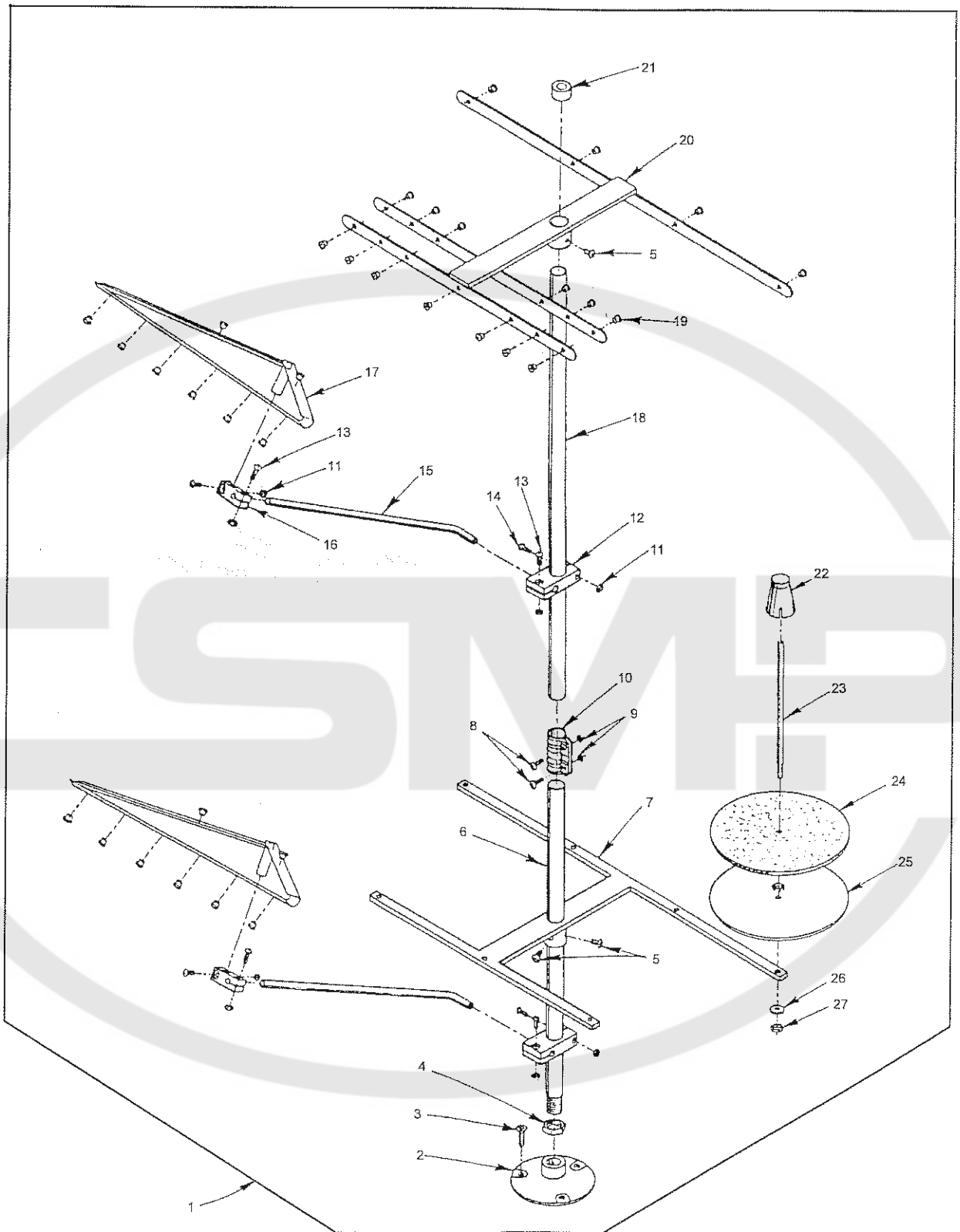

P191-94



## THREAD STAND

Ref. No.	Part No.	Description	Amt. Req.
1.	21101S7	Thread Stand, complete .....	1
2.		Thread Stand Base .....	1
3.		Screw .....	3
4.		Nut .....	1
5.		Screw .....	4
6.		Thread Stand Rod, short .....	1
7.		Base Bracket .....	1
8.		Screw .....	2
9.		Nut .....	2
10.		Joint .....	1
11.		Nut .....	8
12.		Holder, large .....	2
13.		Screw .....	6
14.		Screw, long .....	2
15.		Thread Guide Rod .....	2
16.		Holder, thread guide .....	2
17.		Thread Guide .....	2
18.		Thread Stand Rod, long .....	1
19.		Thread Eyelet .....	34
20.		Thread Guide .....	1
21.		Cap .....	1
22.		Spool Retainer .....	7
23.		Spool Pin .....	7
24.		Felt Disc .....	7
25.		Support Disc .....	7
26.		Spring Washer .....	7
27.		Nut .....	14



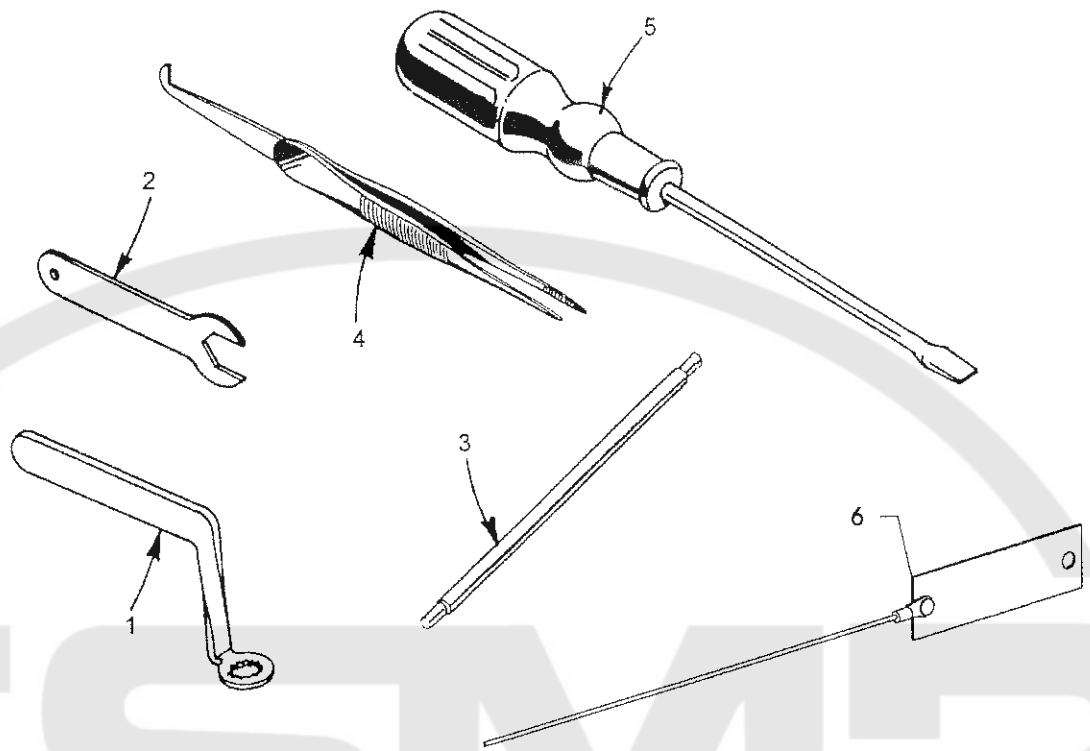

P186-94

ACCESSORIES

Ref. No.	Part No.	Description	Amt. Req.
1.	TT85	Wrench, for looper avoid .....	1
2.	21388AZ	Wrench, for feed bar .....	1
3.	21227AR	Needle Head Torque Rod .....	1
4.	660-240	Thread Tweezers .....	1
5.	21201	Screwdriver .....	1
-	28604R	Oil Can (not shown) .....	1
-	660-1012	Oil Nozzle (not shown) .....	1
-	660-457	Plastic Cover (not shown) .....	1
-	WR56	Allen Wrench, size 1/4" (not shown) .....	1
-	WR58	Allen Wrench, size 3/8" (not shown) .....	1
-	WR60	Allen Wrench, size 1/2" (not shown) .....	1
6.	39899A	Threading Wire .....	1

NUMERICAL INDEX OF PARTS

Part No.	Page No.	Part No.	Page No.	Part No.	Page No.	Part No.	Page No.
109	45	22596	27, 29	23420AY18-3/32	29	35751G	39, 41
110-3	45	22596B	33	23421Y9-1/8	25, 29	35760D	21
11638M	49	22599	51	23421Y9-3/32	29	35760E	21
12934A	19, 31	22644K-80	47	23422AY18-1/8	25	35761	33
136	45	22653E-24	21	23422AY18-1/8	29	35761D	21
14649	43	22711	19	23422AY18-3/32	29	35763F	33
15438C	31	22729C	35, 37, 39	23424AA	25, 29	35763G	33
18	35, 37, 39, 47, 49	22729C	41, 47	23424F	25, 29	35766A	39
20	31, 47	22729D	39	23424S	25, 29	35766B	41
21101S7	53	22730	19	23424T	25, 29	35772S	19
21201	54	22733A	25	23425T	25, 29	35772T	19
21227AR	54	22733B	19	255	45	35792	45
21237ES	43	22733G	37, 41	258	35, 47	35792T	45
21388AZ	54	22738	43	258A	39, 41	35796B	23, 29
21756G	33	22743	35, 49	25B	31	35796C	23, 29
22504C	37	22747	23, 29	269	35, 37, 39, 47	35805BR8	51
22513D	29, 31	22747	35, 37	27-435BLK	23, 29	35805BRW9	51
22516A	19	22752B	39, 41	28	19	35805DP8	51
22517	45	22758C	43, 45	28604R	54	35805DX	51
22519F	33	22758E	31	29101G	35	35808AY	39, 41
22524	23, 27, 31	22759A	19	29103T	37	35809AY	39, 41
22526	39, 41	22760A	25, 29	29103U	37	35809BY	39, 41
22526B	23	22764	35	29105BH	21	35815C	33
22528	37	22766	21, 27	29105BL	21	35816	33
22539AL	25, 27	22768	31, 35, 37	29472AA	33	35817S	31
22539C	25	22784F	45	29472AC	33	35818CB-8	31
22539H	25	22791E	23, 29	29472AD	33	35818CB-9	31
22539T	21	22797	33	29476XK	19	35821S	47
22557A	31	22798	23, 27, 29	29476YR	31	35821V	47
22560A	27, 41	2280	37	29478AH	39	35821X	47
22560B	43, 49	22829	21	29478AJ	39	35822W	33, 47
22561A	23	22839D	45	29478BD	35	35824BQ9	51
22562	43	22845A	51	29478BY	49	35824DN8	51
22562A	39, 41	22845M	37	29478CZ	27	35824DN9	51
22564	33, 39	22849	25, 29	29478DV	37	35824DQ8	51
22564	41, 49	22849A	23, 25	29478DZ	39, 41	35824DQ9	51
22564B	19, 25	22849A	27, 29	29478EB	37	35824DQW9	51
22564J	27	22874C	35	29478EC	41	35824DX8	51
22569B	21	22894AA	37	29478ED	43	35824DX9	51
22570	21	22894AM	33	29478EN	43	35825AC	35, 37
22570A	21	22894BJ	51	29478FL	43	35826CB	43
22571A	25	22894C	43, 47	29480ALY	47	35826DL	51
22571B	33	22894E	47	318	31	35826DP	51
22572	35	22894F	21	33174B	37	35826DX	51
22574	47	22894H	49	35704C	19	35826DZ	43
22580A	35	22894J	33, 45	35722AF	39, 41	35826EF	43
22580D	33	22894K	33	35723C	33	35826X	43
22585A	33, 45	22894P	37	35731A	31	35829AP	31
22585C	29, 43	22894U	41	35733B	45	35830BX8	51
22587B	33	22894W	29, 33, 37	35736A	35	35830BX9	51
22587E	35, 37	22894W	41, 43	35736B	35	35830BXW9	51
22587H	37	22924708	19	35751	39	35830DL9	51
22589	47	23420AY18-1/8	25	35751B	39	35830DM8	51
22594	31	23420AY18-1/8	29	35751F	39	35830DM9	51

NUMERICAL INDEX OF PARTS

<u>Part No.</u>	<u>Page No.</u>	<u>Part No.</u>	<u>Page No.</u>	<u>Part No.</u>	<u>Page No.</u>	<u>Part No.</u>	<u>Page No.</u>
35830DWW8	51	35851G	39	35880L	43	35896B	29
35830DWW9	51	35851P	41	35880N	45	35896D	31
35830DY	51	35851S	41	35880P	45	35897AX	25
35830K	51	35853AA	19	35881AF	21	35897BM	33
35831C	43	35853AD	39	35882J	31	35897BU	33
35833C	45	35853AJ	39, 41	35882K	31	35897BV	33
35833D	45	35853AK	39, 41	35882NR	19	35897BW	33
35833E	45	35853V156	39, 41	35882T	31	35897BY	33
35833F	45	35853W	21	35883A	23	35897CC	33
35834AB	37	35853Y	19	35883AA	27	35897CH	33
35834AC	37	35853Z	19	35883AL	21	35897CK	21, 31
35834G	35	35854A	31	35883E	23	36229A-1	27
35834N	35	35854B	31	35883G	23, 29	36229A1	23
35834R	35	35856Y	27	35883H	23	36234C	37
35834U	35	35862A	33	35883J	23	36234F	37
35834V3	35	35864F	33	35883M	23	36234G	37
35834W	37	35866	39, 41	35883N	27	36234M	37
35834X	37	35866A	21	35883P	27	36236A	37, 41
35835B	35, 37	35866B	21	35883R	29	36236B	37, 41
35835F	43	35866C	21	35883T	27	36236C	41
35836	35	35869C	31	35883U	29	36236G	37
35836A	37	35869D	31	35884E	23	36236H	37, 41
35836C	41	35869K	31	35884F	23	36236J	37
35836L	37	35869L	31	35884H	23	36236K	37
35837A	39	35870	31	35884K	29	36237	37
35837N	39	35871A	21	35884L	25	36237A	37
35837P	31	35871B	21	35884R	23, 27	36237E	27
35838A	31	35871D	21	35884S	31	36237H	27
35838B	31	35873AJ	43	35884T	31	36237J	27
35841B	35	35873AK	43	35886B	25	36237K	27
35842	39	35875AA	43	35886C	25	36237L	29
35842H	39	35875AV	43	35887AE	19	36238	27
35843B	35	35875AW	43	35887AG	19	36238E	27
35844	35	35875X	43	35887AM	31	36244	37
35844C	35	35875Y	43	35887M	19	36244A	37
35844D	35	35875Z	43	35887R	19	36249A	27
35844E	35	35876AB	49	35887X	19	36249B	41
35844N	31	35876AC	49	35887Z	21	36256B	25, 29
35844T	31	35876AD	49	35888L	19	36261A	33
35845D	35	35876AE	49	35888M	19	36278C	41
35846	35	35876AF	49	35888T	19	36280N	45
35846B	35	35876AG	49	35889G	31	36280S	45
35847E	35	35876AH	49	35889H	21	36280T	45
35847X	33	35876U	21	35890E	21	36280U	43
35848B	39, 41	35876V	47	35890M	21	36280V	43
35848D	39, 41	35876W	47	35890Q	21	36280W	45
35848E	39, 41	35877AA	43	35892A	43	36282	29
35849B	39	35877AM	43	35893G	19	36283C	29
35849C	41	35877N	47	35893H	19	36284	23, 27
35850B	23	35877XA	47	35894K	33	36284C	27
35850C	23	35877Z	47	35895V	39, 41	36284E	29
35850G	25, 29	35878F	19	35895W	33	36284F	29
35851	39	35878H	31, 45	35895Y	33	36286	27
35851A	39	35878S	43	35895Z	33	36286B	27



NUMERICAL INDEX OF PARTS

<u>Part No.</u>	<u>Page No.</u>	<u>Part No.</u>	<u>Page No.</u>	<u>Part No.</u>	<u>Page No.</u>
36290B	21	61351C	47, 49	LA527	21
36292K	45	62238A	37, 41	SS4091015SP	31
36292M	45	660-1012	54	SS6121010SP	31
36292N	45	660-1014	21	SS7110510SP	21
36292Q	45	660-1115	25, 27	SS7111120TP	33
36293B	19	660-1117	25, 29	SS7121410TP	31
36293F	19	660-1032	21	SS8120740SP	31
36293G	29	660-199	35	TT85	54
36298G	45	660-206	19	W56392F	45
36298H	45	660-207	41	WC50092S	45
36G	47	660-212	19	WO3	33, 37
376	35	660-219	49	WR56	54
39141	39	660-219S	45	WR58	54
39592AK	45	660-220	27, 37, 39	WR60	54
39899A	54	660-221	35	WZ0641510KP	31
402	43	660-240	54		
41071G	19	660-254C	45		
41255B	37	660-303	43		
41355U	35	660-310	39, 41		
41363U	49	660-457	54		
43246	35	660-548	35		
43296	31	660-935	21		
4761	47	661-150	29		
50-458BLK	39, 41	664F-16	31		
50-834BLK	49	666-149	33		
50-835BLK	49	666-186	47		
50342V	47	666-338	33		
50377L	43	666-340A	31		
51054A	33	666-341	27		
51292F4	45	666-47	35		
51758	23	667D-16	23, 27		
52888B	43	73A	25, 29		
531	23, 25	77	33, 37		
531	27, 29	80557	47		
538	27, 35, 49	8372A	21, 25		
54274C	43	86	43		
54274H	49	87A	27		
54274L	49	87U	25, 29		
54274N	49	87U	35, 37		
54274Y	49	88	25, 35		
54279	49	88	39, 43		
55287L	45	89	31, 39		
56341G	39, 41	90	19, 23, 33		
56354D	33	93	19		
56390E	21	93A	19		
57WB	31	94	45		
57WD	31	98A	19		
60078Z	27	9937	31		
6042A	19, 31	99622A	49		
6042A	39, 47	999-196	29		
605	31	C067E	21		
605A	49	CL21	21, 31		
61321J	47	J87J	23, 27		
61321L	47	K74401	43		

